

GENERALITY



TCS-1 / TCS-2

TCS-3 / TCS-4

MODELS	
TCS1	circuits 24-48Vac/dc / esec. DIN rail 3 modules
TCS2	circuits 110-230-400Vac/dc / esec. DIN rail 3 modules

OPTIONS	
T	tropicalization

MODELS	
TCS3	circuits 24-48Vac/dc / esec. flush mounting DIN 96x96mm
TCS4	circuits 110-230-400Vac/dc / esec. flush mounting DIN 96x96mm

OPTIONS	
T	tropicalization

The **TCS** is devoted to control the MCCB's disconnection circuits (trip) or the safety circuits. In fact, whenever there is an interruption in a circuit (Output relay of any given protection MCCB's shunt trip coil and the connection between the relay and the coil), and it is required that the MCCB trips due to any anomaly in the line, such MCCB will be unable to trip.

Provided that the system has been installed with other protections, some other Circuit Breaker will trip and the result will be the loss of service of other sections of the system, which might be most important.

Should the MCCB be the sole protection, the use of the TCS is most important, because the working guarantee of the tripping circuit becomes critical, in this particular case.

An important application is with the safety or emergency circuits, according with the CEI 64-8/537.4.3 Standard, when using shunt trip coils for emergency reactions, as the starting of a fire fighting

system, por example.

The relay has an auxiliary supply electrically separated from the Control Voltage.

In normal conditions, with auxiliary supply to the TCS relay, the OK green LED will glow. If there is any anomaly on the disconnection or safety circuit, the "ALARM" red LED will glow and the OK green LED will be switched off. The double changeover end relay will be de-energized enabling a possible acustic signal and a remote repetition. Same signal is shown with tripped breaker.

On top of the above it is possible to detect the loss of supply on the auxiliary circuits, by supplying the TCS with same auxiliary voltage.

If the end relay is normally energized (fail safe), when there is a lack of supply, the end relay will be de-energized, as per anomaly situations, but in this case the LED's at the front will be switched off.

ELECTRICAL CHARACTERISTICS

models and value	TCS-1	TCS-2	TCS-3	TCS-4
Auxiliary Voltage supply	24÷48 Vac/dc ± 20%	110-230-400Vac/dc ± 20%	24÷48 Vac/dc ± 20%	110-230-400Vac/dc ± 20%
Frequency	50 ÷ 60 Hz			
Maximum consumption	1,5÷3,5VA depending on Vaux			
Current of circuit under control	6 mA	2 mA 110-380V 4mA 220V	6 mA	2 mA 110-380V 4mA 220V
Voltage of circuit under control	13÷30V ac/dc 8-9 terminals 24÷60V ac/dc 7-9 terminals	50÷260V ac/dc 8-9 terminals 250÷440V ac/dc 7-9 terminals	13÷30V ac/dc 8-9 terminals 24÷60V ac/dc 7-9 terminals	50÷260Vac/dc 8-9 terminals 250÷440Vac/dc 7-9 terminals
Tripping Time delay	0,4÷1 seg. Depending on input Voltage	0,2÷0,5 seg. Depending on input Voltage	0,4÷1 seg. Depending on input Voltage	0,2÷0,5 seg. Depending on input Voltage
Reset Time	0,6÷1seg. Depending on input Voltage	1,5÷2 seg. Depending on input Voltage	0,6÷1seg. Depending on input Voltage	1,5÷2 seg. Depending on input Voltage
Output. 2 change-over contacts	5A 250V			
Working Temperature	-10 + 60°C			
Storing Temperature	-20 + 80°C			
Relative humidity	< 90%			
Insulation Test	2,5 kV 60 sec.			
Pulse Test	5 kV 1,2/50 microsec.			
Standards	CEI 41-1 - IEC 255-801			
Wiring method	Drawing out screw terminals for cross section wires 2,5 mmq			
Protection degree according DIN 40050	IP 20		Ip52	
Mounting according DIN 50022	Snap on DIN rail 35 mm - 3 modules		Flush mounting 96x96mm	
Optional resistance (R) to be used for the monitoring of the circuit also when the switch board is open. The value of the resistance change for the voltage of the circuit.	24 Vac/dc R=0,8÷1kohm 5W 48 Vac/dc R=2,2÷3,3kohm 5w	110 Vac/dc R=8,2÷12kohm 7W 230 Vac/dc R=15÷22kohm 10W 400 Vac/dc R=39÷57kohm 15W	24 Vac/dc R=0,8÷1kohm 5W 48 Vac/dc R=2,2÷3,3kohm 5w	110 Vac/dc R=8,2÷12kohm 7W 230 Vac/dc R=15÷22kohm 10W 400 Vac/dc R=39÷57kohm 15W

DIMENSIONS - TSC-1, TSC-2

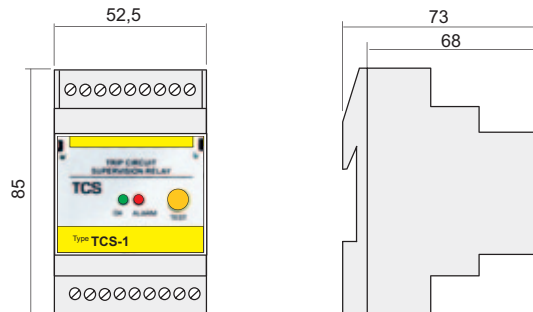

LEGEND - TCS-1, TCS-2

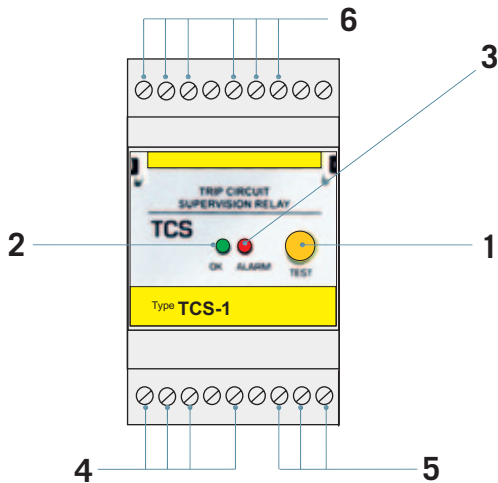

1	Test push button
2	Signalling lamp of OK circuit (green LED)
3	Signalling lamp of anomaly in the circuit (red LED)
4	Terminals for auxiliary supply
5	Connecting terminals to the circuit under control
6	Output terminals of the end relay with double changeover

WIRING DIAGRAM - TCS-1, TCS-2

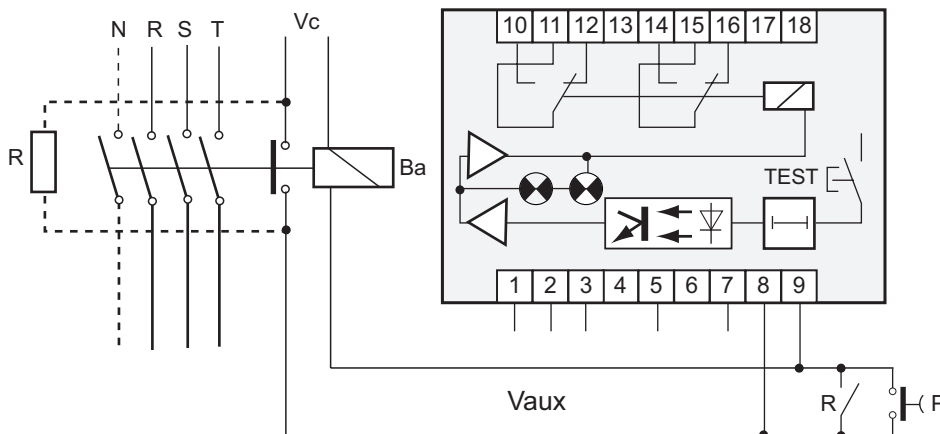

TCS-1

Vaux
 1 - 2 = 24 Vac/dc
 1 - 3 = 48 Vac/dc

Vc
 9 - 8 = 24 Vac/dc
 9 - 7 = 48 Vac/dc

TCS-2

Vaux
 1 - 2 = 110 Vac/dc
 1 - 3 = 220-240 Vac/dc
 1 - 5 = 380-415 Vac/dc

Vc
 9 - 8 = 110-240 Vac/dc
 9 - 7 = 380-415 Vac/dc

DIMENSIONS - TCS-3, TCS-4

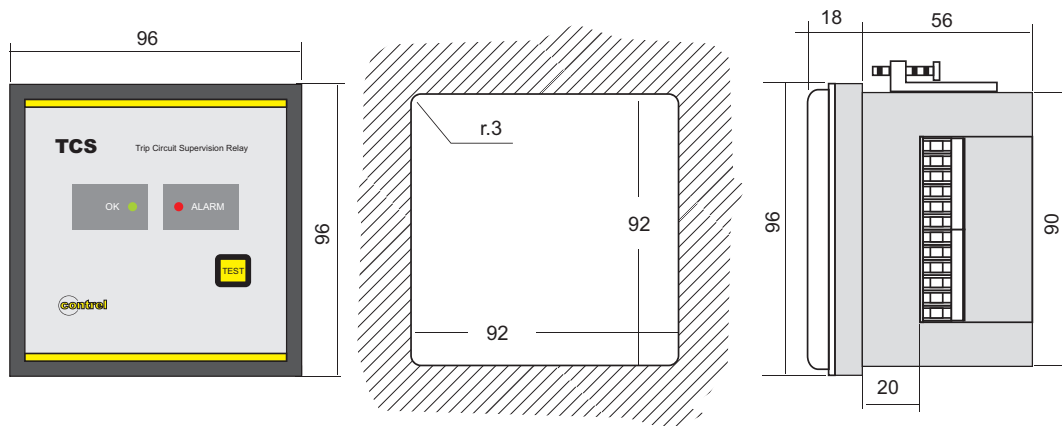

LEGEND - TCS-3, TCS-4

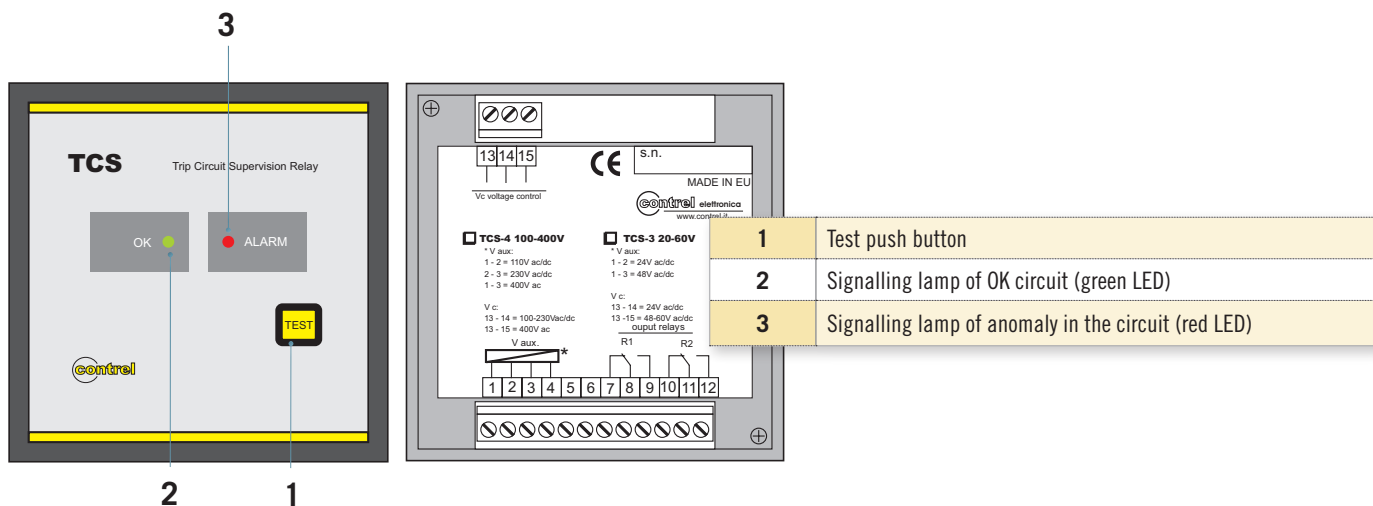

WIRING DIAGRAM - TCS-3, TCS-4

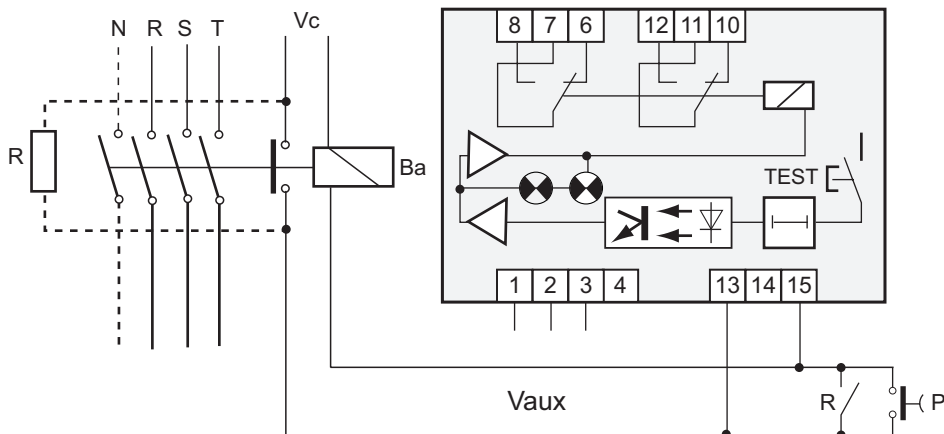

TCS-3

Vaux
 1 - 2 = 24 Vac/dc
 1 - 3 = 48 Vac/dc

Vc
 13 - 14 = 24 Vac/dc
 13 - 15 = 48 Vac/dc

TCS-4

Vaux
 1 - 2 = 110 Vac/dc
 1 - 3 = 230 Vac/dc
 1 - 5 = 400 Vac/dc

Vc
 13 - 14 = 110-230 Vac/dc
 13 - 15 = 400 Vac/dc