

# MULTIFUNCTION VOLTAGE AND FREQUENCY PROTECTION RELAY

## TYPE UM30-A

# OPERATION MANUAL

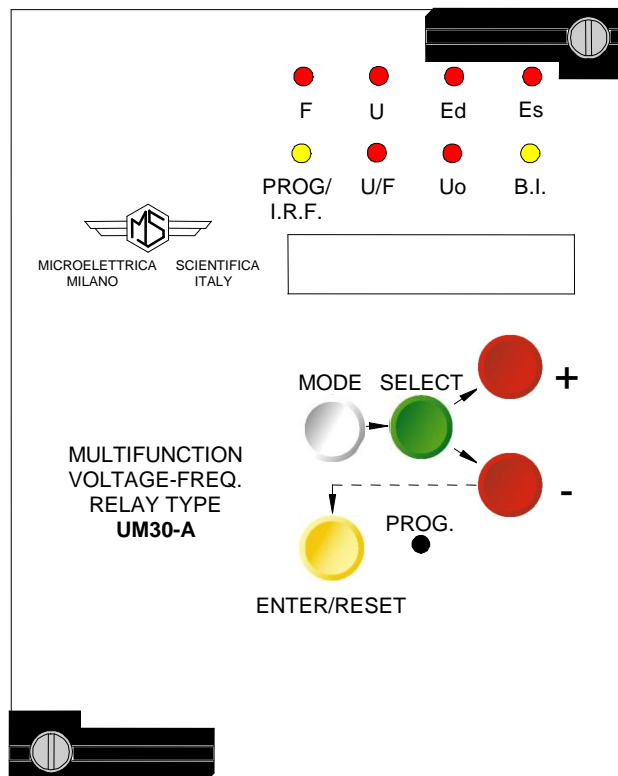

## INDEX

<b>1</b>	<b>General utilization and commissioning directions</b>	<b>3</b>
1.1	Storage and transportation	3
1.2	Installation	3
1.3	Electrical connection	3
1.4	Measuring inputs and power supply	3
1.5	Outputs loading	3
1.6	Protection earthing	3
1.7	Setting and calibration	3
1.8	Safety protection	3
1.9	Handling	3
1.10	Maintenance	4
1.11	Fault detection and repair	4
<b>2</b>	<b>General characteristics and operation</b>	<b>4</b>
2.1	Power supply	4
2.2	Operation and Algorithms	5
2.2.1	Input quantities	5
2.2.2	F24 – Dual level Overfluxing	6
2.2.3	F81 – Dual level over/under frequency	7
2.2.4	F27/59 – Dual level 3-phase over/under voltage	8
2.2.5	F27d/59d – Over/under voltage Sequence Voltage	9
2.2.6	F59s – Negative Sequence Overvoltage	9
2.2.7	F59Uo – Dual level Zero Sequence Overvoltage	9
<b>3</b>	<b>Controls and measurements</b>	<b>10</b>
<b>4</b>	<b>Signalization</b>	<b>11</b>
<b>5</b>	<b>Output relays</b>	<b>12</b>
<b>6</b>	<b>Serial communication</b>	<b>12</b>
<b>7</b>	<b>Digital inputs</b>	<b>13</b>
<b>8</b>	<b>Test</b>	<b>13</b>
<b>9</b>	<b>Keyboard and display operation</b>	<b>14</b>
<b>10</b>	<b>Reading of measurements and recorded parameters</b>	<b>15</b>
10.1	ACT. MEAS (Actual measure)	15
10.2	LAST TRIP (Last trip)	15
10.3	TRIP NUM (Trip number)	16
<b>11</b>	<b>Reading of programmed settings and relay's configuration</b>	<b>16</b>
<b>12</b>	<b>Programming</b>	<b>17</b>
12.1	Programming of functions settings	17
12.2	Programming the configuration of output relay	19
<b>13</b>	<b>Manual and automatic test operation</b>	<b>20</b>
13.1	W/O TRIP	20
13.2	WithTRIP	20
<b>14</b>	<b>Maintenance</b>	<b>20</b>
<b>15</b>	<b>Power frequency insulation test</b>	<b>20</b>
<b>16</b>	<b>Electrical characteristics</b>	<b>21</b>
<b>17</b>	<b>Connection diagram (Standard Output)</b>	<b>22</b>
17.1	Connection Diagram (Double Output)	22
<b>18</b>	<b>Wiring the serial communication bus</b>	<b>23</b>
<b>19</b>	<b>Time current curves V/Hz</b>	<b>24</b>
<b>20</b>	<b>Direction for pcb's draw-out and plug-in</b>	<b>25</b>
20.1	Draw-out	25
20.2	Plug-in	25
<b>21</b>	<b>Overall dimensions / Mounting</b>	<b>26</b>
<b>22</b>	<b>Keyboard operational diagram</b>	<b>27</b>
<b>23</b>	<b>Setting's form</b>	<b>28</b>

## 1. General utilization and commissioning directions

Always make reference to the specific description of the product and to the Manufacturer's instruction. Carefully observe the following warnings.

### 1.1 - STORAGE AND TRANSPORTATION

must comply with the environmental conditions stated on the product's instruction or by the applicable IEC standards.

### 1.2 - INSTALLATION

must be properly made and in compliance with the operational ambient conditions stated by the Manufacturer.

### 1.3 - ELECTRICAL CONNECTION

must be made strictly according to the wiring diagram supplied with the Product, to its electrical characteristics and in compliance with the applicable standards particularly with reference to human safety.

### 1.4 - MEASURING INPUTS AND POWER SUPPLY

carefully check that the value of input quantities and power supply voltage are proper and within the permissible variation limits.

### 1.5 - OUTPUTS LOADING

must be compatible with their declared performance.

### 1.6 - PROTECTION EARTHING

When earthing is required, carefully check its effectiveness.

### 1.7 - SETTING AND CALIBRATION

Carefully check the proper setting of the different functions according to the configuration of the protected system, the safety regulations and the co-ordination with other equipment.

### 1.8 - SAFETY PROTECTION

Carefully check that all safety means are correctly mounted, apply proper seals where required and periodically check their integrity.

### 1.9 - HANDLING

Notwithstanding the highest practicable protection means used in designing M.S. electronic circuits, the electronic components and semiconductor devices mounted on the modules can be seriously damaged by electrostatic voltage discharge which can be experienced when handling the modules. The damage caused by electrostatic discharge may not be immediately apparent but the design reliability and the long life of the product will have been reduced.

The electronic circuits reduced by M.S. are completely safe from electrostatic discharge (8 KV IEC 255.22.2) when housed in their case; withdrawing the modules without proper cautions expose them to the risk of damage.

- a. Before removing a module, ensure that you are at the same electrostatic potential as the equipment by touching the case.
- b. Handle the module by its front-plate, frame, or edges of the printed circuit board. Avoid touching the electronic components, printed circuit tracks or connectors.
- c. Do not pass the module to any person without first ensuring that you are both at the same electrostatic potential. Shaking hands achieves equipotential.
- d. Place the module on an antistatic surface, or on a conducting surface which is at the same potential as yourself.
- e. Store or transport the module in a conductive bag.

More information on safe working procedures for all electronic equipment can be found in BS5783 and IEC 147-OF.

### 1.10 - MAINTENANCE

Make reference to the instruction manual of the Manufacturer ;maintenance must be carried-out by specially trained people and in strict conformity with the safety regulations.

### 1.11 - FAULT DETECTION AND REPAIR

Internal calibrations and components should not be altered or replaced.  
For repair please ask the Manufacturer or its authorised Dealers.

Misapplication of the above warnings and instruction relieves the Manufacturer of any liability.

## 2. GENERAL

The measured quantities are supplied from 3 Wye-connected system's P.Ts to the 3 input transformers; the zero sequence voltage is built-up internally.

The relay is normally supplied for 100V phase-to-phase input. Any different input voltage is available on request. The rated input voltage is marked on the relay's P.C. board as well as on the connection diagram printed on its enclosure.

Make electric connection in conformity with this diagram and check that input voltages are same as reported on the diagram and on the test certificate.

The auxiliary power is supplied by a built-in interchangeable module fully isolated and self protected.

### 2.1 - POWER SUPPLY

The relay can be fitted with two different types of **power supply** module :

- |                             |                             |                             |
|-----------------------------|-----------------------------|-----------------------------|
| a) - {                      | {                           | b) - {                      |
| 24V(-20%) / 110V(+15%) a.c. | 80V(-20%) / 220V(+15%) a.c. | 90V(-20%) / 250V(+20%) d.c. |
| 24V(-20%) / 125V(+20%) d.c. | 90V(-20%) / 250V(+20%) d.c. |                             |

Before energising the unit check that supply voltage is within the allowed limits.

## 2.2 – Operation and Algorithms

### 2.2.1 – Input quantities

#### System Frequency

The relay can be programmed to work at Rated Frequency 50Hz or 60Hz.  
(Frequency measuring range from 40Hz through 70Hz)

#### Voltage inputs

The relay measures the Phase-to-Neutral voltages “EA, EB, EC”; and computes the phase-to-phase voltages as vector summation of the relevant phase-to-neutral voltages:

$$U_A (U_{AB} = \bar{E}_A - \bar{E}_B), \quad U_B (U_{BC} = \bar{E}_B - \bar{E}_C), \quad U_C (U_{CA} = \bar{E}_C - \bar{E}_A)$$

The above values are directly displayed as primary voltages at the high voltage side of the system Potential Transformers. To make the relay properly working with any P.T., when programming the relay settings, we have to input the value of the P.Ts. Rated Primary Phase-to-Phase Voltage “**UnP**” (adjustable from 0.1kV to 655kV) as well as the P.Ts. Rated Secondary Phase-to-Phase Voltage “**UnS**” (adjustable from 100V to 400V).

#### Positive and Negative Sequence Components

Based on the measurement of  $\bar{E}_A$ ,  $\bar{E}_B$ ,  $\bar{E}_C$  the relay computes the Positive Sequence Component “**Ed**” and the Negative Sequence Component “**Es**” of the three-phase System.

These components are displayed as % of the rated Phase-to-Neutral voltage  $E_n (U_n/\sqrt{3})$

#### Zero Sequence Residual Voltage (3Vo)

The Relay computes the Zero Sequence Residual voltage “Uo” as the vector summation of the three phase-to-neutral voltage phasors.

$$U_o = 3V_o = \bar{E}_A + \bar{E}_B + \bar{E}_C$$

**2.2.2 - F24 – Dual level Overfluxing (see curve § 19)**

The relay computes the ratio  $\Phi = \frac{V}{\text{Hz}}$  of the input voltage to input frequency and compares it to the relay rated value  $\frac{U_n}{F_n}$

**1F 24** : Inverse Time element

- Minimum pick-up level :  $1\Phi > = (1 - 2) \frac{U_n}{F_n}$ , step 0.1pU
- Time multiplier :  $K = (0.5 - 5)$ , step 0.1
- Trip time delay :  $t = \frac{K}{\left(\frac{V}{\text{Hz}} - 1\Phi >\right)} + 0.5$  (see curve §19)
- Operation blocked :  $(1\Phi > = \text{Dis})$

**2F 24** : Definite Time element

- Minimum pick-up level :  $2\Phi > = (1 - 2) \frac{U_n}{F_n}$ , step 0.1pU
- Independent time delay :  $t_{2\Phi} = (0.1 - 60)\text{s}$ , step 0.1s
- Operation blocked :  $(2\Phi > = \text{Dis})$

For both levels:

- Undervoltage inhibition :  $U < 0.1U_n$

**2.2.3 - F81 - Dual level over/under frequency****1F 81** : First frequency element  $f'$ 

- Minimum Pick-up level frequency difference :  $f' = (0.05-9.99)\text{Hz}$ , step 0.01Hz
- Independent trip time delay :  $1f' = (0.1-60)\text{s}$ , step 0.1s
- Operation mode :  $(F_n \pm f')$

The function can be programmed to operate as :

- Overfrequency ( $F_n + f'$ ) : operates when the frequency rises above the rated value  $[F_n]$  by more than  $f'$  Hz.  $f \geq (F_n + f')\text{Hz}$
- Underfrequency ( $F_n - f'$ ) : operates when the frequency drops below the rated value  $[F_n]$  by more than  $f'$  Hz.  $f \leq (F_n - f')\text{Hz}$
- Frequency balance ( $F_n \pm f'$ ) : operates when frequency differs from rated value by more than  $f'$  Hz.  $(F_n - f')\text{Hz} \geq f \geq (F_n + f')\text{Hz}$
- Operation blocked :  $(F_n = \text{Dis})$
- Undervoltage inhibition :  $U < 0.1U_n$

**2F F81** : Second frequency element  $f''$ 

It operates same as the first element ; the programmable parameters are :

- Pick-up level :  $f'' = (0.05-9.99)\text{Hz}$ , step 0.01Hz
- Independent trip time delay :  $tf'' = (0.1-60)\text{s}$ , step 0.1s
- Operation mode :  $(F_n \pm f'')$

**2.2.4 - F27/59 : Dual level 3-phase over/under voltage**
**1F 27-59 : First voltage element u'**

- Minimum Pick-up level voltage difference level :  $u' = (5-50)\%U_n$ , step 1%
- Independent trip time delay :  $tu' = (0.1-60)s$ , step 0.1s
- Operation mode :  $(U_n \ +/- \ u')$

The function can be programmed to operate as :

- Overvoltage ( $U_n + u'$ ) : operates when any phase voltage  $E_x$  exceeds the rated value  $\frac{[U_n]}{\sqrt{3}}$  by more than  $[u']\%$ .

$$\frac{\sqrt{3} \cdot E_x}{[U_n]} \cdot 100 \geq (100 + [u'])\%$$

- Undervoltage ( $U_n - u'$ ) : operates when any phase voltage  $E_x$  drops below the rated value  $\frac{[U_n]}{\sqrt{3}}$  by more than  $[u']\%$ .

$$\frac{\sqrt{3} \cdot E_x}{[U_n]} \cdot 100 \leq (100 - [u'])\%$$

- Voltage balance ( $U_n \ +/- \ u'$ ) : operates when any phase voltage differs from the rated value more then  $[u']\%$

$$(100 - [u'])\% \geq \frac{\sqrt{3} \cdot E_x}{[U_n]} \cdot 100 \geq (100 + [u'])\%$$

- Operation blocked :  $(U_n = \text{Dis})$

**2F 27-59 : Second voltage element u''**

It operates same as the first element; the programmable variables are :

- Pick-up level :  $u'' = (5-50)\%U_n$ , step 1%
- Independent trip time delay :  $tu'' = (0.1-60)s$ , step 0.1s
- Operation mode :  $(U_n \ +/- \ u'')$



**2.2.5 - F27d/59d : Over/under voltage Positive Sequence Voltage**

- Minimum Pick-up level voltage difference level : **Ed** = (5-90)%En, step 1%
- Independent trip time delay : **tEd** = (0.1-60)s, step 0.1s
- Operation mode : (Edn +/- Ed)

The function can be programmed to operate as :

- Overvoltage (Edn + Ed) : operates when the Positive Sequence voltage Component exceeds the set value :  $Ed \geq (En + [Ed])$
- Undervoltage (Edn - Ed): operates when the Positive Sequence voltage Component drops below the set value :  $Ed \leq (En - [Ed])$
- Voltage balance (Edn +/- Ed) : operates when the Positive Sequence voltage Component exceed the set limits:  

$$(En - [Ed]) \geq Ed \geq (En + [Ed])$$
- Operation blocked : [Edn = Dis]

**2.2.6 - F59s : Negative Sequence Overvoltage**

- Minimum Pick-up level : **Es** = (1-99)%En, step 1%En
- Independent trip time delay : **tEs** = (0.1-60)s, step 0.1s
- Operates when :  $Es \geq [Es]$
- Operation blocked : (Es = Dis)

**2.2.7 – F59Uo – Dual level Zero Sequence Overvoltage**

As already explained the relay computes the Zero Sequence Residual voltage  $U_o = 3V_o$  as vector summation of the three phase-to-neutral phasors.

The relay is also capable to discriminate which is the phase where the Earth Fault occurred and this indication is given in the Event Recording file (See § 10.2) where the cause of tripping is displayed.

F64 – First element

- Minimum pick-up level : **Uo>** = (1-99)%Un, adjustable in steps of 1%Un
- Independent trip time delay : **tO>** = (0.05-60)s, adjustable step of 0.05/0.1s

F64 – Second element

- Minimum pick-up level : **Uo>>** = (1-99)%Un, adjustable in steps of 1%Un
- Independent trip time delay : **tO>>** = (0.05-9.9)s, adjustable step of 0.05/0.1s

**3. CONTROLS AND MEASUREMENTS**

Five key buttons allow for local management of all relay's functions.

A 8-digit high brightness alphanumerical display shows the relevant readings (xxxxxxx)

(see synoptic table fig.1)

**Fig.1**

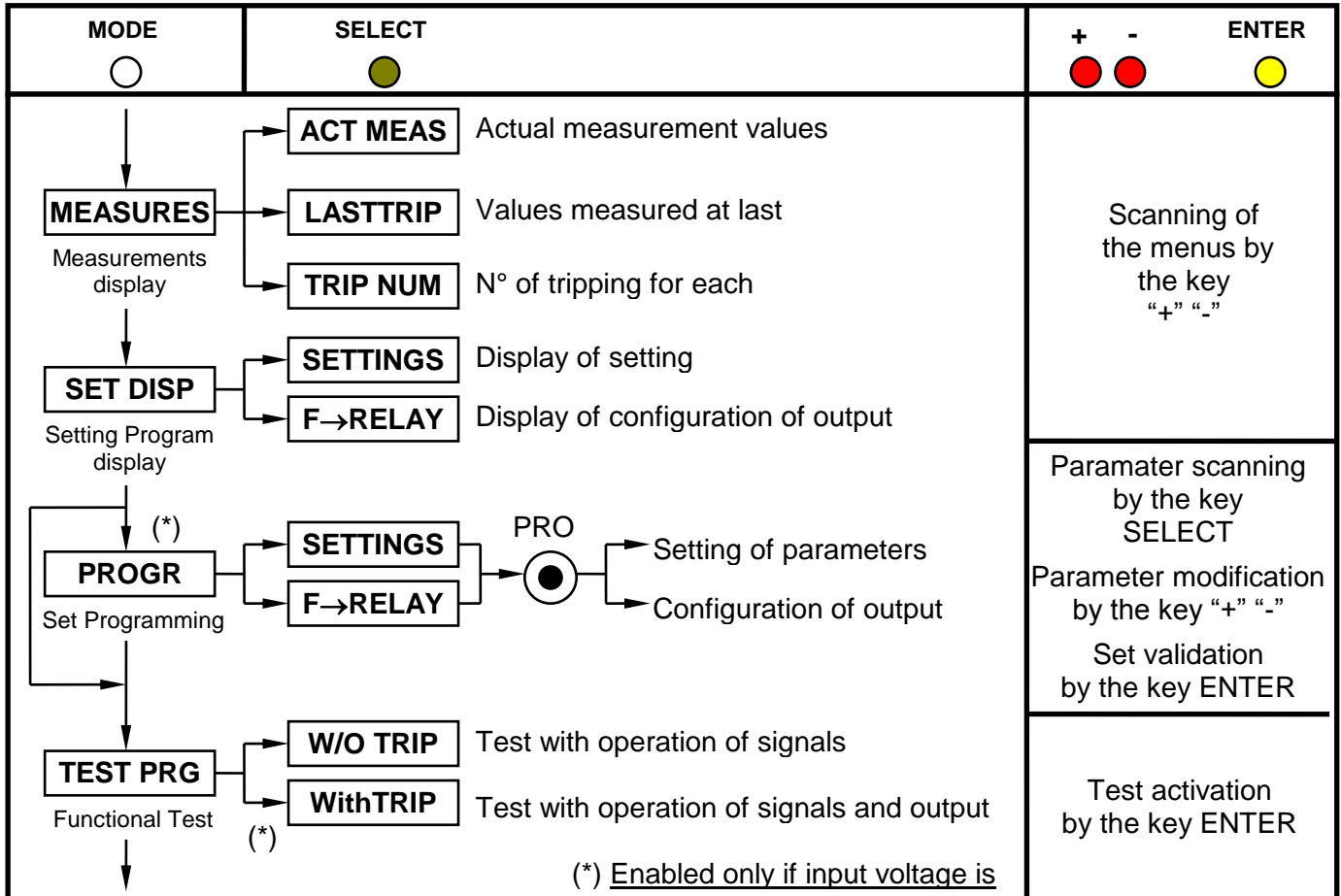

Pressing this button progressively selects between Measurements Display, Setting Display, Programming, and Test modes

The SELECT button chooses which category of values within the chosen mode to display

When in Program mode, this button stores the newly selected value. If not in Program mode and the relay has tripped, this button resets the relay and all output contacts. If not tripped, this button restores the default display.

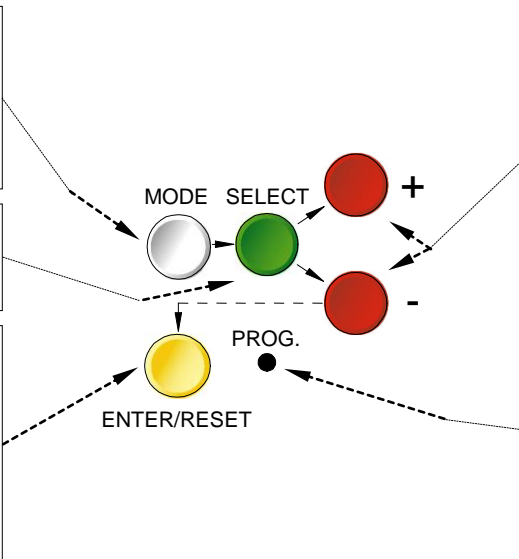

The + and - buttons are used to select the actual measurement or display desired when in Measurements Display or Settings Display modes. When in Program mode, these buttons increase or decrease the value of the displayed setting.

When in Program mode, and when all input currents are zero, pressing this recessed button places the relay into active programming mode, allowing any or all of the relay's settings to be altered.

**4. SIGNALIZATIONS**

Eight signal leds (normally off) are provided:

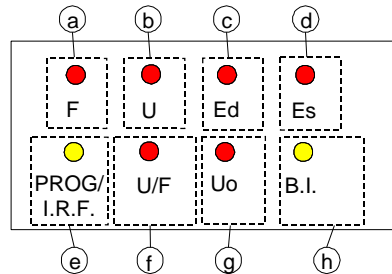

a) Red LED	<b>F</b>	<input type="checkbox"/> Flashing as soon as one of the two frequency control elements starts to operate <input type="checkbox"/> Lit-on at the end of the set time delay
b) Red LED	<b>U</b>	<input type="checkbox"/> As above, for the two voltage control elements
c) Red LED	<b>Ed</b>	<input type="checkbox"/> As above, for the direct sequence voltage control element
d) Red LED	<b>Es</b>	<input type="checkbox"/> As above, for the negative sequence voltage control element
e) Yellow LED	<b>U/F</b>	<input type="checkbox"/> As above, for the V/Hz ratio control element
f) Red LED	<b>Uo</b>	<input type="checkbox"/> As above, for the two zero sequence voltage control elements
g) Red LED	<b>PRG./ I.R.F.</b>	<input type="checkbox"/> Flashing when programming; lit-on in case of internal fault detected during relay's autotest.
h) Yellow LED	<b>B.I.</b>	<input type="checkbox"/> Lit-on when a blocking signal input is present (BI).

**The reset of the leds takes place as follows:**

<input type="checkbox"/> Leds a,b,c,d,e,f	:	<input type="checkbox"/> From flashing to off, when the start cause disappears. <input type="checkbox"/> From lit-on to off, by the "ENTER/RESET" push button or via serial bus only if the tripping cause has been cleared.
<input type="checkbox"/> Leds g,h	:	<input type="checkbox"/> From flashing/lit-on to off, automatically when the lit-on cause disappears.

In case of auxiliary power supply failure the status of the leds is recorded and reproduced when power supply is restored.

At switch-on of auxiliary power the relay performs an automatic self diagnostic test routine during which all signal leds are lit-on and the display shows the type of the relay.

If no internal fault has been detected, after a few seconds the leds are turned off and the display is turned to its default indication.

	<b>UM30-A</b>	Doc. N° MO-0020-ING	
		Rev.	<b>6</b>
		Date	<b>25.06.2003</b>

## 5. OUTPUT RELAYS

Five output relays are available (R1, R2, R3, R4, R5) for external signalization and trip.

- a) - The relays **R1, R2, R3, R4** are normally deenergized (energized on trip): one or more of them can be associated to one or more of the UM30's functions (programmable configuration). One relay associated to more than one function will be operated by the function which is set to operate first.  
The reset after trip can only take place if the relevant tripping cause has been cleared.  
The reset function is programmable as follows :
- Automatic instantaneous (Rxtr AUT.)
  - Automatic after adjustable time delay 0,1 to 9,9 sec. (Rxtr x,x s)
  - Manual (Rxtr MAN.) : in this mode the reset is operated either by the ENTER/RESET push button on the relay's front face or via serial bus
- b) - The relay **R5**, normally energized, is not programmable and it is deenergized on:
- internal fault
  - power supply failure
  - during the programming

## 6. SERIAL COMMUNICATION (Optional: see relevant instruction manual)

The relays fitted with the serial communication option can be connected via a cable bus or (with proper adapters) a fiber optic bus for interfacing with a Personal Computer (type IBM or compatible). All the operations which can be performed locally (for example reading of measured data and changing of relay's settings) are also possible via the serial communication interface. Furthermore the serial port allows the user to read the demand recording data. The unit has a RS232 / RS485 interface and can be connected either directly to a P.C. via a dedicated cable or to a RS485 serial bus, thus having many relays to exchange data with a single master P.C. using the same physical serial line. A RS485/232 converter is available on request. The communication protocol is MODBUS RTU (only functions 3, 4 and 16 are implemented). Each relay is identified by its programmable address code (NodeAd) and can be called from the P.C. A dedicated communication software (MSCOM) for Windows 95/98/NT4 SP3 (or later) is available. Please refer to the MSCOM instruction manual for more information.

## 7. DIGITAL INPUT

Two blocking inputs activated by external cold contacts are available at relay's terminal board.

- 
- **BI>** (terminals 1 - 2) : Inhibits the operation of the output relays controlled by the "over level" functions (F>, U>, Ed>, Es>, Uo>, Uo>>,U/F) as long as it is active. As soon as the blocking input is removed the output relays associated to functions actually in operation will trip either instantaneously or after the remaining time delay if any. (\*)
- 
- **BI<** (terminals 1 - 3) : When active, inhibits the operation of all the "under level" functions (F<, U<, Ed<) including their timers. As soon as the blocking input is removed the timers of the functions eventually in operation, start counting and relevant output relays trip at the end of the set time delay. (\*)
- 

(\*) If the blocking input is activated before the input quantity has overpassed the operation level of the function blocked, the timing does not start at all.

## 8. TEST

Besides the normal "WATCHDOG" and "POWERFAIL" functions, a comprehensive program of self-test and self-diagnostic provides:

- Diagnostic and functional test, with checking of program routines and memory's content, run every time the aux. power is switched-on: the display shows the type of relay and its version number.
- Dynamic functional test run during normal operation every 15 min. (relay's operation is suspended for less than  $\leq 4$  ms). If any internal fault is detected, the display shows a fault message, the Led "PROG/IRF" illuminates and the relay R5 is deenergized.
- Complete test activated by the keyboard or via the communication bus either with or without tripping of the output relays.

**9. KEYBOARD AND DISPLAY OPERATION**

All controls can be operated from relay's front or via serial communication bus.

The keyboard includes five hand operable buttons (**MODE**) - (**SELECT**) - (**+**) - (**-**) - (**ENTER/RESET**) plus one indirect operable key (**PROG**) (see synoptic table a fig.1):

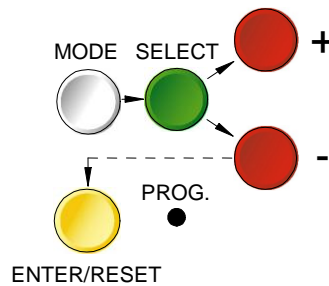

a) - White key	<b>MODE</b>	: when operated it enters one of the following operation modes indicated on the display :
	<b>MEASURES</b>	= Reading of all the parameters measured and of those recorded in the memory
	<b>SET DISP</b>	= Reading of the settings and of the configuration of the output relays as programmed.
	<b>PROG</b>	= Access to the programming of the settings and of relay configuration.
	<b>TEST PROG</b>	= Access to the manual test routines.
b) - Green key	<b>SELECT</b>	: When operated it selects one of the menus available in the actual operation MODE
c) - Red key	<b>“+” AND “-”</b>	: When operated they allow to scroll the different information available in the menu entered by the key <b>SELECT</b>
d) - Yellow key	<b>ENTER/RESET</b>	: It allows the validation of the programmed settings - the actuation of test programs - the forcing of the default display indication - the reset of signal Leds.
e) - Indirect key	●	: Enables access to the programming.

## 10. READING OF MEASUREMENTS AND RECORDED PARAMETERS

Enter the MODE "MEASURE", SELECT the menu "ACT.MEAS" or "LAST TRIP" or "TRIP NUM", scroll available information by key "+" or "-".

### 10.1 - ACT.MEAS

Actual values as measured during the normal operation. The values displayed are continuously refreshed.

Display		Description
<b>F</b>	xx.xx Hz	Input frequency : 40,00 - 70,00 Hz
<b>UA</b>	xx V,kV	R.M.S. value of system's phase-to-phase voltage UA-B : 0-999V or 0-9,99kV or 0-999kV with automatic scale selection (kV showed as K)
<b>UB</b>	xx V,kV	As above UB-C
<b>UC</b>	xx V,kV	As above UC-A
<b>Uo</b>	xxx %Un	Residual voltage at secondary of system's P.Ts. : 0,0-999,9V (Uo = 3 x Eo)
<b>EA</b>	xx V,kV	R.M.S. value of system's phase A-to neutral voltage 0-999kV
<b>EB</b>	xx V,kV	As above phase B
<b>EC</b>	xx V,kV	As above phase C
<b>Ed</b>	xxx %En	Direct sequence component of voltage as % of system's rated voltage: 0-999%
<b>Es</b>	xxx %En	Negative sequence component of voltage as above

### 10.2 - LAST TRIP

Display of the function which caused the last tripping of the relay plus values of the parameters at the moment of tripping. The memory buffer is refreshed at each new relay tripping.

Display		Description
<b>Cau:</b>	xxxx	Display of the time delayed function which has operated the last tripping --f' = 1st frequency element --f'' = 2nd frequency element --u' = 1st voltage element --u'' = 2nd voltage element -O>A or O>B or O>C = 1st zero sequence element for earth fault on phase A or B or C O>>A or O>>B or O>>C = as above 2nd level --Ed = Direct sequence voltage element --Es = Negative sequence voltage element --1Φ = V/Hz 1st element --2Φ = V/Hz 2nd element
<b>F</b>	xx.xx Hz	Frequency as measured at the instant of last trip
<b>UA</b>	xxx V,kV	Voltage UA-B as measured at the instant of last trip
<b>UB</b>	xxx V,kV	As above UB-C
<b>UC</b>	xxx V,kV	As above UC-A
<b>Uo</b>	xxx % Un	As above UO
<b>Ed</b>	xxx %En	As above ED
<b>Es</b>	xxx %En	As above ES

## 10.3 - TRIP NUM

Counters of the number of operations for each of the relay functions.  
 The memory is non-volatile and can be cancelled only with a secret procedure.

Display	Description
<b>f'</b> xxxxx	First frequency delayed element [t1f.]
<b>f''</b> xxxxx	Second frequency delayed element [t2f.]
<b>u'</b> xxxxx	First voltage delayed element [t1u.]
<b>u''</b> xxxxx	Second voltage delayed element [t2u.]
<b>Uo'</b> xxxxx	Low set residual voltage (3Eo)delayed element [tO']
<b>Uo''</b> xxx	High set residual voltage (3Eo)delayed element [tO'']
<b>Ed</b> xxxxx	Direct sequence voltage delayed element [tEd]
<b>Es</b> xxxxx	Negative sequence voltage delayed element [tEs]
<b>1Φ</b> xxxxx	V/Hz delayed 1st element [tU/F]
<b>2Φ</b> xxxxx	V/Hz delayed 2nd element [tU/F]

## 11. READING OF PROGRAMMED SETTINGS AND RELAY'S CONFIGURATION

Enter the mode "SET DISP", select the menu "SETTINGS" or "F→RELAY", scroll information available in the menu by keys "+" or "-".

SETTINGS= values of relay's operation parameters as programmed

F→RELAY= output relays associated to the different functions as programmed.



## 12. PROGRAMMING

The relay is supplied with the standard default programming used for factory test.

[ Values here below reported in the " Display " column ].

All parameters can be modified as needed in the mode PROG and displayed in the mode SET DISP  
**Local Programming by the front face key board is enabled only if no input voltage is detected (main switch open).**

Programming via the serial port is always enabled but a password is required to access the programming mode. The default password is the null string; in the standard application program for communication "MS-COM" it is also provided an emergency which can be disclosed on request only. As soon as programming is enabled, the Led PRG/IRF flashes and the reclosing lock-out relay R5 is deenergized. Enter MODE "PROG" and SELECT either "SETTINGS" for programming of parameters or "F→RELAY" for programming of output relays configuration; enable programming by the indirect operation key PROG.

The key SELECT now scrolls the available parameters. By the key (+) , (-) the displayed values can be modified; to speed up parameter's variation press the key SELECT while "+" or "-" are pressed. Press key "ENTER/RESET" to validate the set values.

### 12.1 - PROGRAMMING OF FUNCTIONS SETTINGS

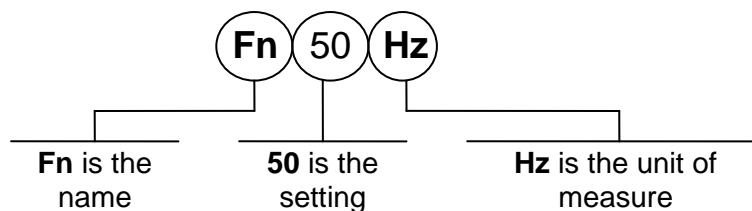

Mode PROG menu SETTINGS. (Production standard settings here under shown).

Display	Description	Setting Range	Step	Unit
<b>Fn</b> 50 <b>Hz</b>	System frequency	50-60	10	Hz
<b>UnP</b> 10 <b>kV</b>	Rated primary phase-to-phase voltage of system's P.Ts.	0.10 - 655	(0,1-1) 0,01 (1.1-9.9) 0.1 (10-655) 1	kV
<b>UnS</b> 100 <b>V</b>	Rated secondary phase-to-phase voltage of system's P.Ts	100 - 400	1	V
<b>1Φ&gt;</b> 1.2 <b>pU</b>	Trip level of the V/Hz 1st element	1 - 2 - Dis	0.1	pU
<b>K</b> 5.0	Time delay coefficient of the function 1Φ>	0,5 - 5	0.1	-
<b>2Φ&gt;</b> 1,2 <b>pU</b>	Trip level of the V/Hz 2nd element	1 - 2 - Dis	0.1	pU
<b>t2Φ</b> 5.0 <b>s</b>	Time delay of the function 2Φ> definite time	0.1 - 60	0.1	s
<b>Fn</b> -/+ <b>f'</b>	Operation mode of the first frequency control element - = underfrequency + = overfrequency -/+ = under/over frequency Dis = function is disactivated	- + -/+ Dis	-	-

Display	Description	Setting Range	Step	Unit
<b>f'</b> 0.50 <b>Hz</b>	Trip differential level of the 1st frequency control element	0.05 - 9.99	0.01	Hz
<b>tf'</b> 1.0 <b>s</b>	Trip time delay of first frequency control element	0.1 - 60.0	0.1	s
<b>Fn</b> - <b>f''</b>	Operation mode of the second freq. control element - = underfrequency + = overfrequency -/+ = under/over frequency Dis = function is disactivated	- + -/+ Dis	-	-
<b>f''</b> 1.00 <b>Hz</b>	Trip differential level of the 2nd freq. element	0.05 - 9.99	0.01Hz	Hz
<b>tf''</b> 2.0 <b>s</b>	Trip time delay of 2nd freq. control element	0.1 - 60	0.1	s
<b>F27/59</b> U	Operation of function 27/59 on phase-to-phase voltage (U) or phase-to-neutral voltage (E)	U - E	-	-
<b>Un</b> -/+ <b>u'</b>	Operation mode of the first voltage control element - = undervoltage + = overvoltage -/+ = under/over voltage Dis = function is disactivated	- + -/+ Dis	-	-
<b>u'</b> 10 <b>%Un</b>	Trip differential level of the 1st voltage control element	5 - 90	1	%Un
<b>tu'</b> 1.0 <b>s</b>	Trip time delay of 1st voltage control element	0.1 - 60	0.1	s
<b>Un</b> + <b>u''</b>	Operation mode of the 2nd voltage control element - = undervoltage + = overvoltage -/+ = under/over voltage Dis = function is disactivated	- + -/+ Dis	-	-
<b>u''</b> 20 <b>%Un</b>	Trip differential level of the 2nd voltage control element	5 - 90	1	%Un
<b>tu''</b> 2,0 <b>s</b>	Time delay of 2nd voltage control element	0.1 - 60	0.1	s
<b>Edn</b> -/+ <b>Ed</b>	Operation mode of the direct sequence voltage element - = undervoltage + = overvoltage -/+ = under/over voltage Dis = function is disactivated	- + -/+ Dis	-	-
<b>Ed</b> 20 <b>%En</b>	Trip differential level of the direct sequence element	5 - 90	1	%En
<b>tEd</b> 5,0 <b>s</b>	Trip time delay of the direct sequence element	0.1 - 60	0.1	s
<b>Es</b> 10 <b>%En</b>	Trip level of the negative sequence voltage element	1-99-Dis	1	%En
<b>tEs</b> 5.0 <b>s</b>	Trip time delay of the negative sequence element	0.1 - 60	0.1	s
<b>Uo'</b> 10 <b>%Un</b>	Trip level of the low-set residual voltage (3xEo) element (Volts at PT's secondary)	1 - 99 - Dis	1	%Un
<b>to'</b> 0,50 <b>s</b>	Trip time delay of low-set residual voltage element	0.05-60	(0.05-9.9) 0.05 (10-60) 0.1	s
<b>Uo''</b> 20 <b>%Un</b>	Trip level of the high-set residual voltage element	1 - 99 - Dis	1	%Un
<b>to''</b> 0.20 <b>s</b>	Trip time delay of high-set residual voltage element	0.05 - 9.9	0.05	s
<b>NodAd</b> 1	Identification number for connection on serial communication bus	1 - 250	1	-

**The setting Dis indicates that the function is disactivated.**

## 12.2 - PROGRAMMING THE CONFIGURATION OF OUTPUT RELAYS

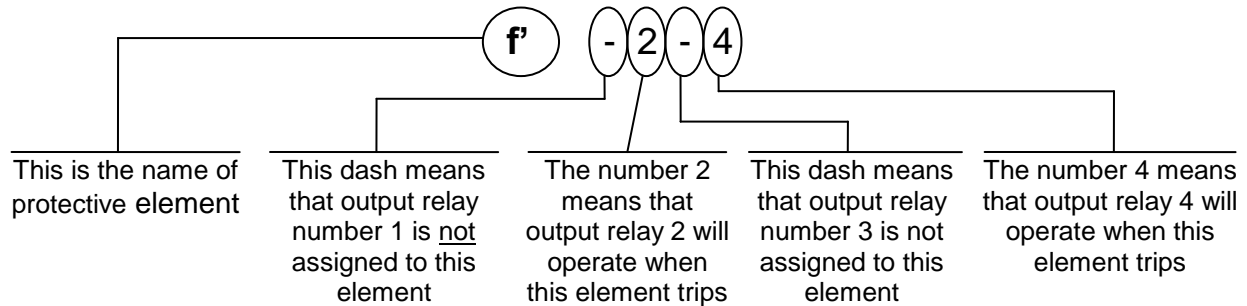

Mode PROG menu F→RELAY (Production standard settings here under shown).

The key "+" operates as cursor; it moves through the digits corresponding to the four programmable relays in the sequence 1,2,3,4,(1= relay R1, etc.) and makes start flashing the information actually present in the digit. The information present in the digit can be either the number of the relay (if this was already associated to the function actually on programming) or a dot (-) if the relay was not yet addressed.

The key "-" changes the existing status from the dot to the relay number or viceversa.

Display	Descrizione
f' - - - 4	Instantaneous element of 1st frequency level. Minimum time delay 80ms. operates relay R1,R2,R3,R4.
tf' 1 - - -	As above, time delayed element. operates relay R1,R2,R3,R4.
f" - - - 4	Instantaneous element of 2nd frequency level. Minimum time delay 80ms. operates relay R1,R2,R3,R4.
tf" - 2 - -	As above, time delayed element. operates relay R1,R2,R3,R4.
u' - - - 4	Instantaneous element of 1st voltage level operates relay R1,R2,R3,R4.
tu' 1 - - -	As above, time delayed element. operates relay R1,R2,R3,R4.
u" - - - 4	Instantaneous element of 2nd voltage level operates relay R1,R2,R3,R4.
tu" - 2 - -	As above, time delayed element. operates relay R1,R2,R3,R4.
Uo' - - - 4	Instantaneous elements of low-set earth fault level operates relay R1,R2,R3,R4.
to' 1 - - -	As above, time delayed element operates relay R1,R2,R3,R4.
Uo" - - - 4	Instantaneous element of high-set earth fault level operates relay R1,R2,R3,R4.
to" - - 3 -	As above, time delayed element operates relay R1,R2,R3,R4.
Ed - - - 4	Instantaneous element of direct sequence voltage level operates relay R1,R2,R3,R4.
tEd - - 3 -	As above, time delayed element. operates relay R1,R2,R3,R4.
Es - - - 4	Instantaneous element of negative seq. voltage level operates relay R1,R2,R3,R4.
tEs - - 3 -	As above, time delayed element. operates relay R1,R2,R3,R4.
1Φ - - - 4	Instantaneous element of the 1Φ> element (only one or more whatever combination). operates relay R1,R2,R3,R4.
t1Φ - - 3 -	As above, time delayed 1Φ> element operates relay R1,R2,R3,R4.
2Φ - - - 4	Instantaneous element of the 2Φ> element operates relay R1,R2,R3,R4.
t2Φ - - 3 -	As above, time delayed 2Φ> element operates relay R1,R2,R3,R4.
R1tr 3 s	Reset time delay of output relay R1 can be: - instantaneous (R1tr Aut.) - time delayed (R1tr 0,1- 9,9 s) step 0,1 s (3 s delay showed) - manual (R1tr Man.)
R2tr Aut.	As above for relay R2.
R3tr Man	As above for relay R3.
R4tr Aut.	As above for relay R4.

## 13. MANUAL AND AUTOMATIC TEST OPERATION

### 13.1 Mode "TESTPROG" subprogram "W/O TRIP"

Operation of the yellow key activates a complete test of the electronics and the process routines. All the leds are lit-on and the display shows (TEST RUN). If the test routine is successfully completed the display switches-over to the default reading (FxxxxHz). If an internal fault is detected, the display shows the fault identification code and the relay R5 is deenergized. This test can be carried-out even during the operation of the relay without affecting the relay tripping in case a fault takes place during the test itself.

### 13.2 Mode "TESTPROG" subprogram "WithTRIP"

Access to this program is enabled only if the voltage measured is zero (breaker open). Pressing the yellow key the display shows "TEST RUN?". A second operation of the yellow key starts a complete test which also includes the activation of all the output relays. The display shows (TEST RUN) with the same procedure as for the test with **W/O TRIP**. Every 15 min during the normal operation the relay automatically initiates an auto test procedure (duration  $\leq 10$ ms). If any internal fault is detected during the auto test, the relay R5 is deenergized, the relevant led is activated and the fault code is displayed.

- Further operation of key SELECT instead of the TEST programs gives the indication of the version and production date of the firmware.



### WARNING

Running the **WithTRIP** test will operate all of the output relays. Care must be taken to ensure that no unexpected or harmful equipment operations will occur as a result of running this test. It is generally recommended that this test be run only in a bench test environment or after all dangerous output connections are removed.

## 14. MAINTENANCE

No maintenance is required. Periodically a functional check-out can be made with the test procedures described under MANUAL TEST chapter. In case of malfunctioning please contact Microelettrica Scientifica Service or the local Authorised Dealer mentioning the relay's Serial No reported in the label on relays enclosure.

## 15. POWER FREQUENCY INSULATION TEST

Every relay individually undergoes a factory insulation test according to IEC255-5 standard at 2 kV, 50 Hz 1min.

Insulation test should not be repeated as it unusefully stresses the dielectrics.

When doing the insulation test, the terminals relevant to serial output must always be short circuited to ground.

When relays are mounted in switchboards or relay boards that have to undergo the insulation tests, the relay modules must be drawn-out of their enclosures and the test must only include the fixed part of the relay with its terminals and the relevant connections.

This is extremely important as discharges eventually taking place in other parts or components of the board can severely damage the relays or cause damages, not immediately evident to the electronic components.

## 16. ELECTRICAL CHARACTERISTICS

**APPROVAL: CE – RINA – UL and CSA approval File : E202083**

**REFERENCE STANDARDS IEC 60255 - EN50263 - CE Directive - EN/IEC61000 - IEEE C37**

<input type="checkbox"/> Dielectric test voltage	IEC 60255-5	2kV, 50/60Hz, 1 min.
<input type="checkbox"/> Impulse test voltage	IEC 60255-5	5kV (c.m.), 2kV (d.m.) – 1,2/50µs
<input type="checkbox"/> Insulation resistance	> 100MΩ	

### Environmental Std. Ref. (IEC 68-2-1 - 68-2-2 - 68-2-33)

<input type="checkbox"/> Operation ambient temperature	-10°C / +55°C
<input type="checkbox"/> Storage temperature	-25°C / +70°C
<input type="checkbox"/> Humidity	IEC68-2-3 RH 93% Without Condensing AT 40°C

### CE EMC Compatibility (EN50081-2 - EN50082-2 - EN50263)

<input type="checkbox"/> Electromagnetic emission	EN50222 industrial environment			
<input type="checkbox"/> Radiated electromagnetic field immunity test	IEC61000-4-3	level 3	80-1000MHz	10V/m
	ENV50204		900MHz/200Hz	10V/m
<input type="checkbox"/> Conducted disturbances immunity test	IEC61000-4-6	level 3	0.15-80MHz	10V
<input type="checkbox"/> Electrostatic discharge test	IEC61000-4-2	level 4	6kV contact / 8kV air	
<input type="checkbox"/> Power frequency magnetic test	IEC61000-4-8		1000A/m	50/60Hz
<input type="checkbox"/> Pulse magnetic field	IEC61000-4-9		1000A/m, 8/20µs	
<input type="checkbox"/> Damped oscillatory magnetic field	IEC61000-4-10		100A/m, 0.1-1MHz	
<input type="checkbox"/> Electrical fast transient/burst	IEC61000-4-4	level 3	2kV, 5kHz	
<input type="checkbox"/> HF disturbance test with damped oscillatory wave (1MHz burst test)	IEC60255-22-1	class 3	400pps, 2,5kV (m.c.), 1kV (d.m.)	
<input type="checkbox"/> Oscillatory waves (Ring waves)	IEC61000-4-12	level 4	4kV(c.m.), 2kV(d.m.)	
<input type="checkbox"/> Surge immunity test	IEC61000-4-5	level 4	2kV(c.m.), 1kV(d.m.)	
<input type="checkbox"/> Voltage interruptions	IEC60255-4-11			
<input type="checkbox"/> Resistance to vibration and shocks	IEC60255-21-1 - IEC60255-21-2 10-500Hz 1g			

### CHARACTERISTICS

<input type="checkbox"/> Accuracy at reference value of influencing factors	2% Un for measure 2% +/- 10ms for times
<input type="checkbox"/> Rated Voltage	(100 ÷ 400)Vac phase to phase
<input type="checkbox"/> Voltage overload	500Vac continuous
<input type="checkbox"/> Burden on voltage input	0,2 VA /phase at Vn
<input type="checkbox"/> Average power supply consumption	8.5 VA
<input type="checkbox"/> Output relays	rating 5 A; Vn = 380 V A.C. resistive switching = 1100W (380V max) make = 30 A (peak) 0,5 sec. break = 0.3 A, 110 Vcc, L/R = 40 ms (100.000 op.)

Microelettrica Scientifica S.p.A. - 20089 Rozzano (MI) - Italy - Via Alberelle, 56/68  
 Tel. (##39) 02 575731 - Fax (##39) 02 57510940

<http://www.microelettrica.com> e-mail : [ute@microelettrica.com](mailto:ute@microelettrica.com)

*The performances and the characteristics reported in this manual are not binding and can modified at any moment without notice*

**17. CONNECTION DIAGRAM (SCE1342 Rev.5 Standard Output)**

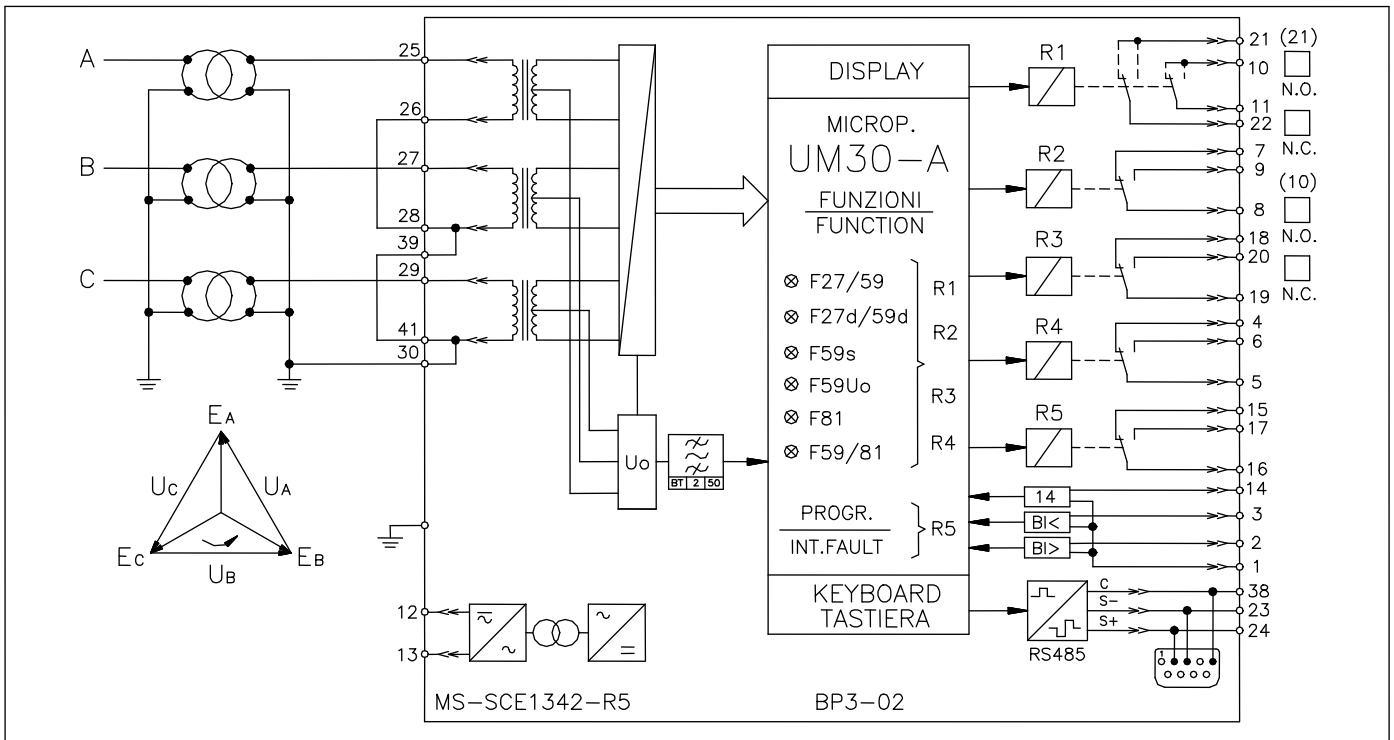

**17.1 CONNECTION DIAGRAM (SCE1451 Rev.2 Double Output)**

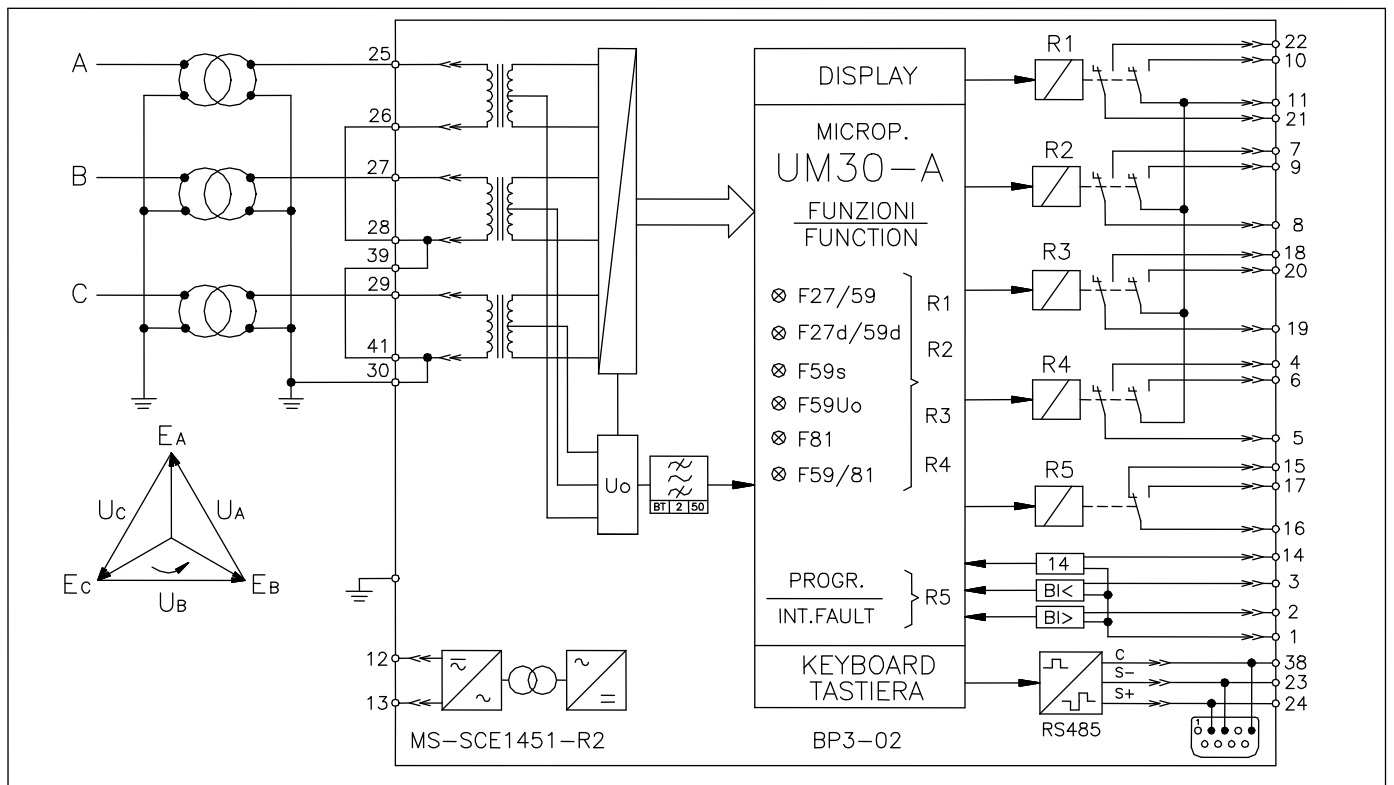

**18. WIRING THE SERIAL COMMUNICATION BUS (SCE1309 Rev.0)**

CONNECTION TO RS485

FIBER OPTIC CONNECTION

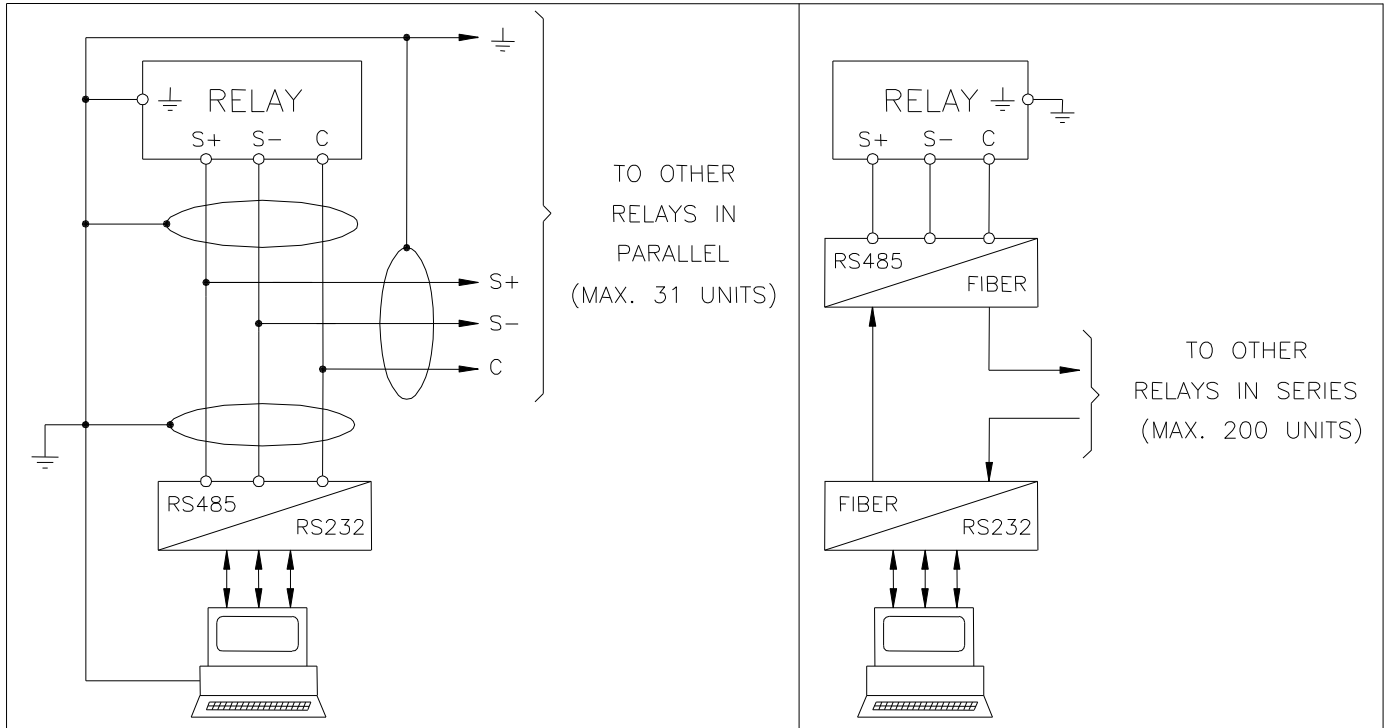

**19. TIME CURRENT CURVES V/Hz (TU0326 Rev.1)**

CARATTERISTICA DI INTERVENTO  
TIME/V:Hz CURVES

$$1\Phi > = 1.1 \text{ pU}$$

$$K = 1.2$$

$$2\Phi > = 1.2 \text{ pU}$$

$$t2\Phi = 2.5 \text{ s}$$

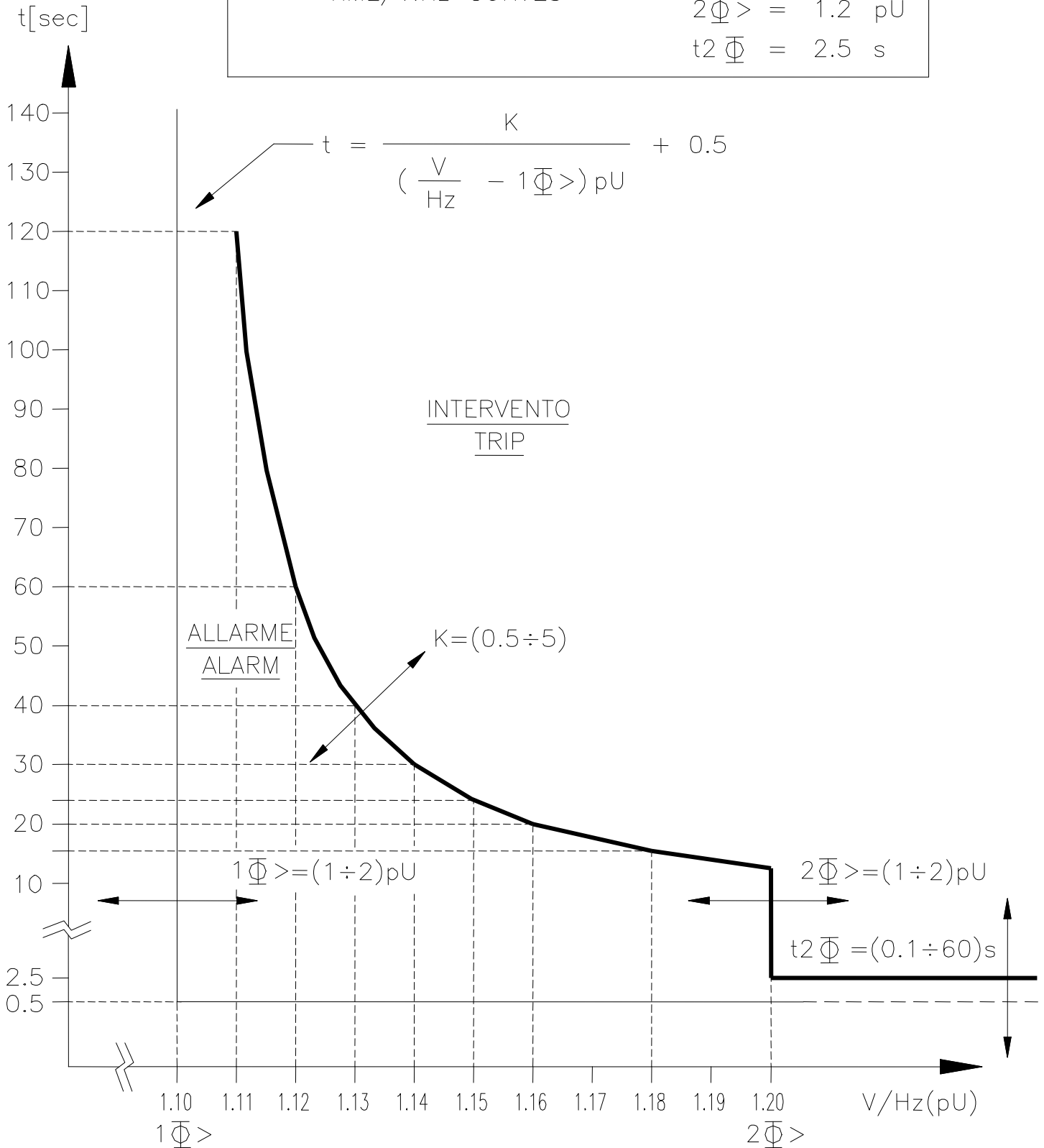



**20. DIRECTION FOR PCB'S DRAW-OUT AND PLUG-IN**

**20.1 Draw-out**

Rotate clockwise the screws ① and ② in the horizontal position of the screws-driver mark.  
Draw-out the PCB by pulling on the handle ③

**20.2 Plug-in**

Rotate clockwise the screws ① and ② in the horizontal position of the screws-driver mark.  
Slide-in the card on the rails provided inside the enclosure.  
Plug-in the card completely and by pressing the handle to the closed position.  
Rotate anticlockwise the screws ① and ② with the mark in the vertical position (locked).

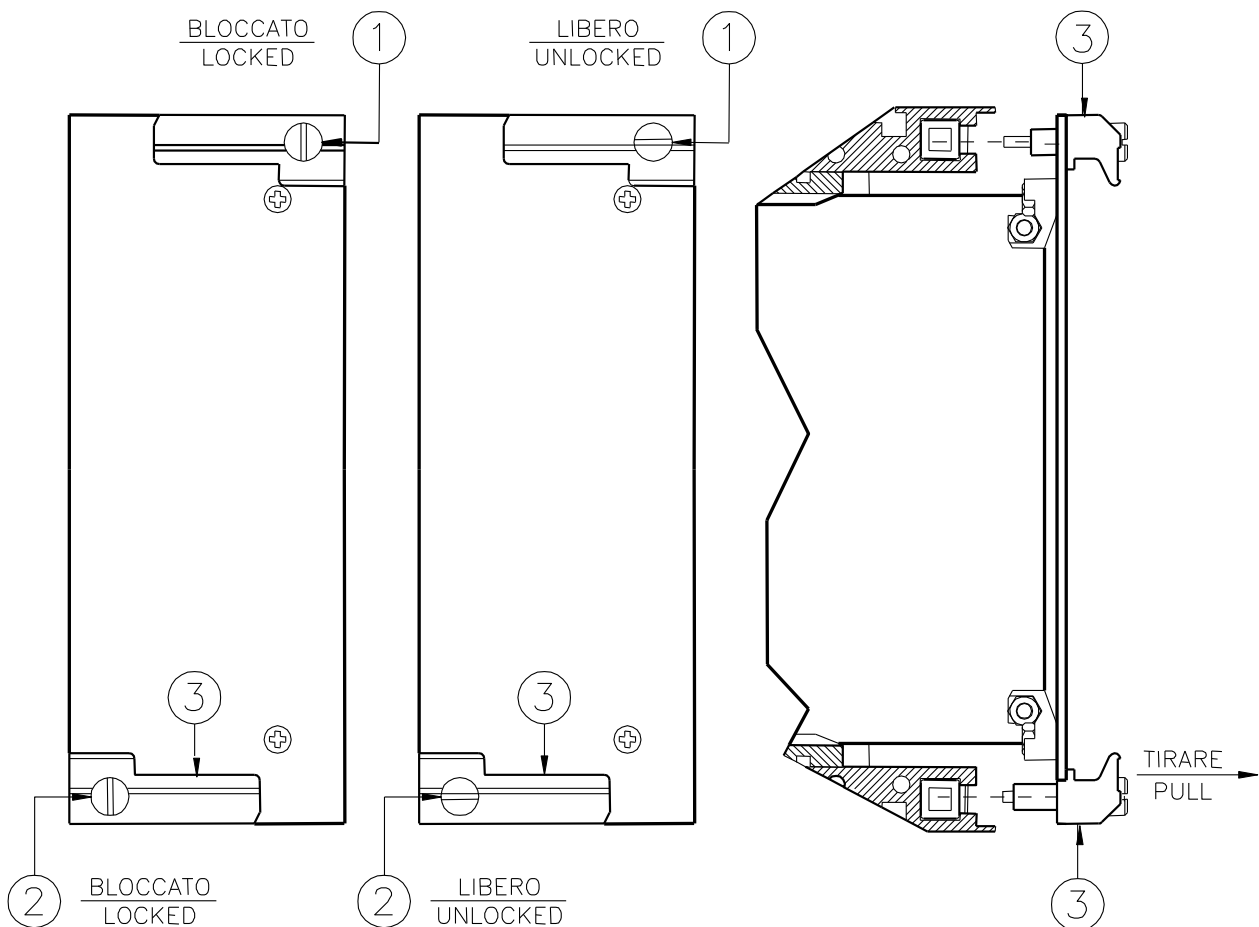

**21. OVERALL DIMENSIONS / MOUNTING**

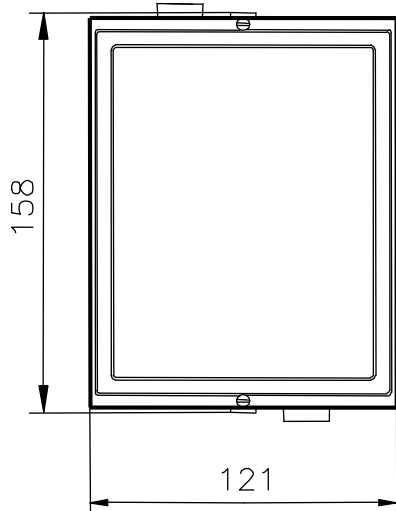

PANEL CUT-OUT 113x142 (LxH)

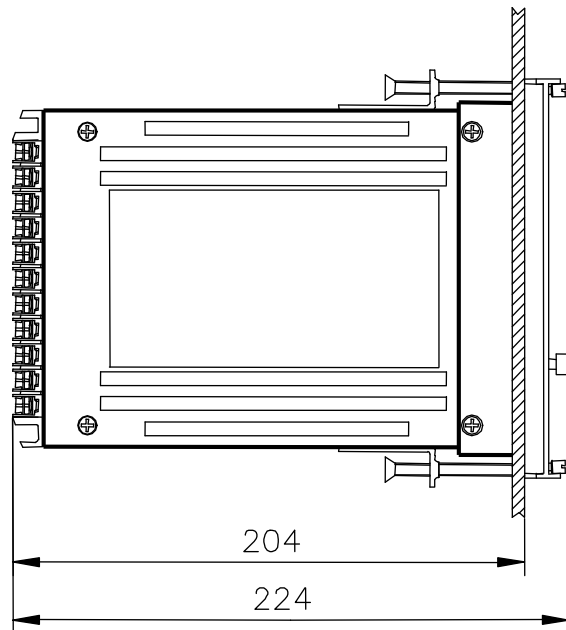

**View of Rear Terminal Connection**

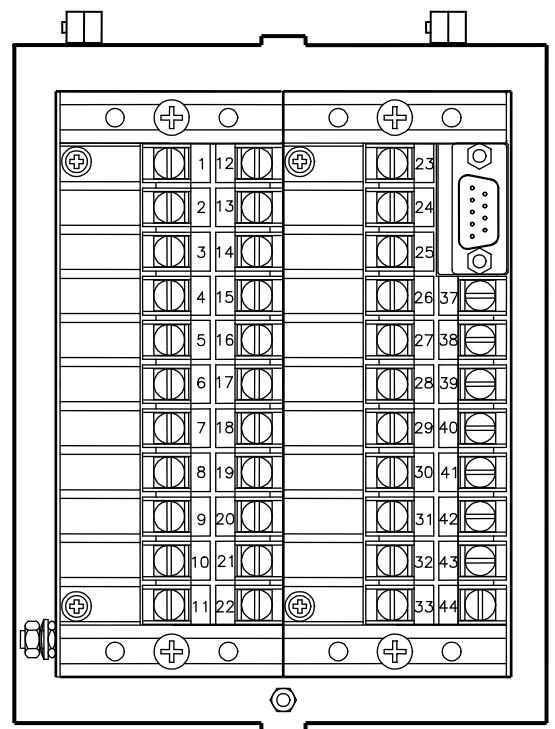
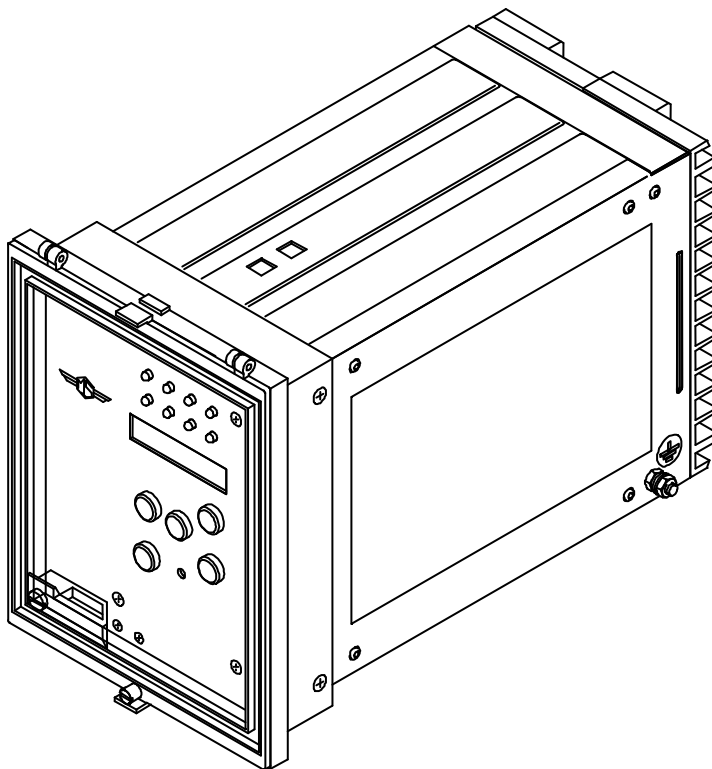

22. KEYBOARD OPERATIONAL DIAGRAM

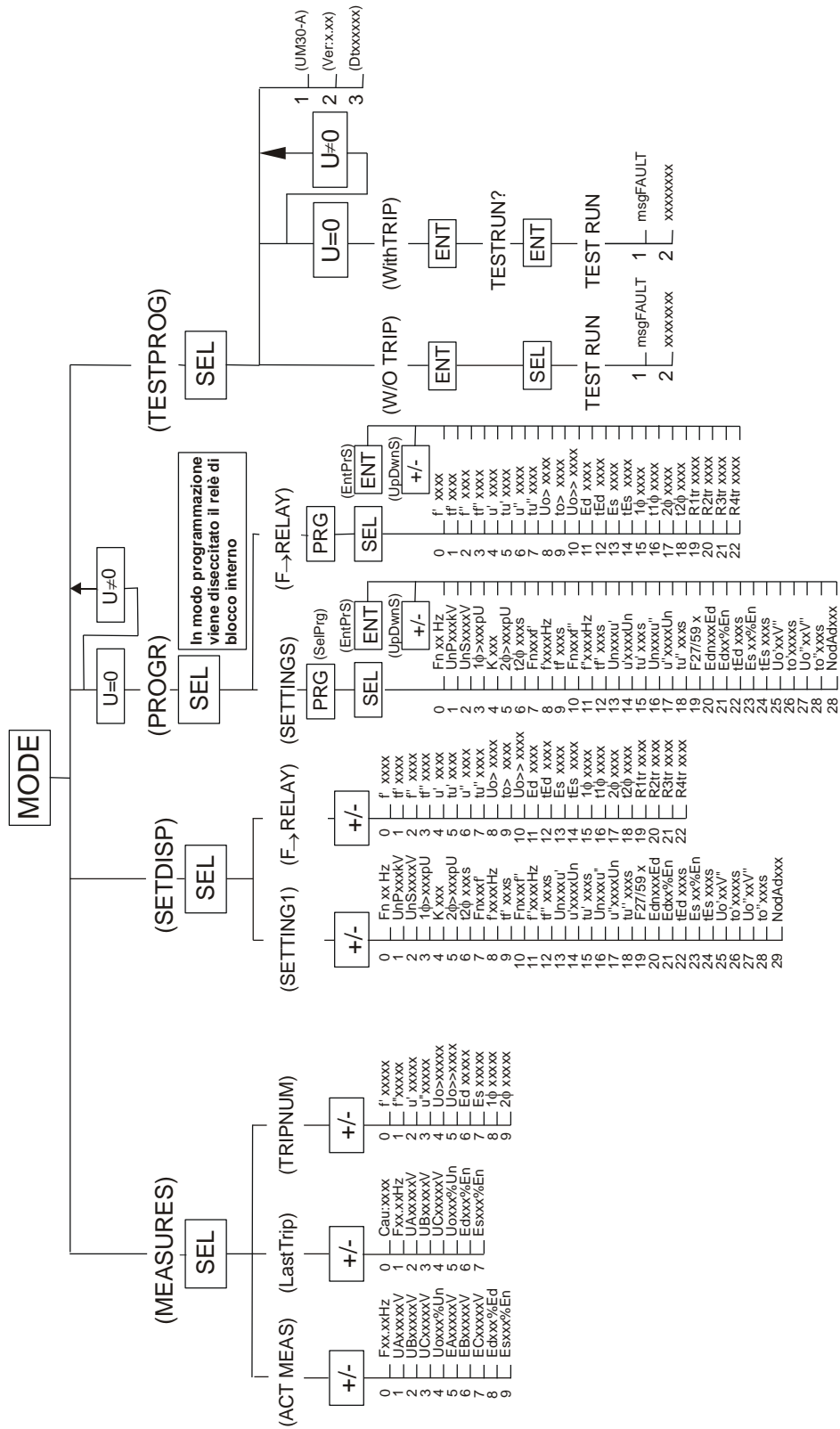

**23. Setting Form – Commissioning Test Record**

<b>Relay Type</b>	<b>UM30-A</b>	<b>Station :</b>	<b>Circuit :</b>				
<b>Date :</b>	/	/	<b>Relay Serial Number :</b>				
<b>Power Supply</b>	<input type="checkbox"/>	24V(-20%) / 110V(+15%) a.c. 24V(-20%) / 125V(+20%) d.c.			<b>Rated Voltage :</b>		
	<input type="checkbox"/>	80V(-20%) / 220V(+15%) a.c. 90V(-20%) / 250V(+20%) d.c.					
<b>RELAY PROGRAMMING</b>							
Variable	Description	Setting Range	Default Setting	Actual Setting	Test Result		
					Pick-up	Reset	
<b>Fn</b>	System frequency	50-60 Hz	50				
<b>UnP</b>	Rated primary phase-to-phase voltage of system's P.Ts.	0.10 - 655 kV	10				
<b>UnS</b>	Rated secondary phase-to-phase voltage of system's P.Ts	100 - 400 V	100				
<b>1Φ&gt;</b>	Trip level of the V/Hz 1st element	1 - 2 - Dis pU	1,2				
<b>K</b>	Time delay coefficient of the function 1Φ>	0,5 - 5 -	5,0				
<b>2Φ&gt;</b>	Trip level of the V/Hz 2nd element	1 - 2 - Dis pU	1,2				
<b>t2Φ</b>	Time delay of the function 2Φ> definite time	0.1 - 60 s	5,0				
<b>Fn</b>	Operation mode of the first frequency control element	- + -/+ Dis f'	-/+				
<b>f'</b>	Trip differential level of the 1st frequency control element	0.05 - 9.99 Hz	0,50				
<b>tf'</b>	Trip time delay of first frequency control element	0.1 - 60.0 s	1,0				
<b>Fn</b>	Operation mode of the second freq. control element	- + -/+ Dis f''	-				
<b>f''</b>	Trip differential level of the 2nd freq. element	0.05 - 9.99 Hz	1,00				
<b>tf''</b>	Trip time delay of 2nd freq. control element	0.1 - 60 s	2,0				
<b>F27/59</b>	Operation of function 27/59 on phase-to-phase voltage (U) or phase-to-neutral voltage (E)	U - E -	U				
<b>Un</b>	Operation mode of the first voltage control element	- + -/+ Dis u'	-/+				
<b>u'</b>	Trip differential level of the 1st voltage control element	5 - 90 %Un	10				
<b>tu'</b>	Trip time delay of 1st voltage control element	0.1 - 60 s	1,0				
<b>Un</b>	Operation mode of the 2nd voltage control element	- + -/+ Dis u''	+				
<b>u''</b>	Trip differential level of the 2nd voltage control element	5 - 90 %Un	20				
<b>tu''</b>	Time delay of 2nd voltage control element	0.1 - 60 s	2,0				
<b>Edn</b>	Operation mode of the direct sequence voltage element	- + -/+ Dis Ed	-/+				
<b>Ed</b>	Trip differential level of the direct sequence element	5 - 90 %En	20				
<b>tEd</b>	Trip time delay of the direct sequence element	0.1 - 60 s	5,0				
<b>Es</b>	Trip level of the negative sequence voltage element	1-99-Dis %En	10				
<b>tEs</b>	Trip time delay of the negative sequence element	0.1 - 60 s	5,0				
<b>Uo'</b>	Trip level of the low-set residual voltage (3xEo) element (Volts at PT's secondary)	1 - 99 - Dis %Un	10				
<b>to'</b>	Trip time delay of low-set residual voltage element	0.05-60 s	0,50				
<b>Uo''</b>	Trip level of the high-set residual voltage element	1 - 99 - Dis %Un	20				
<b>to''</b>	Trip time delay of high-set residual voltage element	0.05 - 9.9 s	0,20				
<b>NodAd</b>	Identification number for connection on serial communication bus	1 - 250 -	1				

## CONFIGURATION OF OUTPUT RELAYS

Default Setting		Description	Actual Setting			
Protect. Element	Output Relays		Protect. Element	Output Relays		
f'	- - - 4	As above, time delayed element.	f'			
tf'	1 - - -	Instantaneous element of 2nd frequency level	tf'			
f''	- - - 4	As above, time delayed element.	f''			
tf''	- 2 - -	Instantaneous element of 1st voltage level	tf''			
u'	- - - -	Instantaneous element of 1st voltage level	u'			
tu'	1 - - -	As above, time delayed element.	tu'			
u''	- - - 4	Instantaneous element of 2nd voltage level	u''			
tu''	- 2 - -	As above, time delayed element.	tu''			
Uo>	- - - 4	Instantaneous elements of low-set earth fault	Uo>			
to>	1 - - -	As above, time delayed element	to>			
Uo>>	- - - 4	Instantaneous element of high-set earth fault	Uo>>			
to>>	- - 3 -	As above, time delayed element	to>>			
Ed	- - - 4	Instantaneous element of direct sequence voltage level	Ed			
tEd	- - 3 -	As above, time delayed element.	tEd			
Es	- - - 4	Instantaneous element of negative seq. voltage level	Es			
tEs	- - 3 -	As above, time delayed element.	tEs			
1Φ	- - - 4	Instantaneous element of the 1Φ> element	1Φ			
t1Φ	- - 3 -	As above, time delayed 1Φ> element	t1Φ			
2Φ	- - - 4	Instantaneous element of the 2Φ> element	2Φ			
t2Φ	- - 3 -	As above, time delayed 2Φ> element	t2Φ			
R1tr	3s	Reset time delay of output relay R1	R1tr			
R2tr	Aut.	Reset time delay of output relay R2	R2tr			
R3tr	Man.	Reset time delay of output relay R3	R3tr			
R4tr	Aut.	Reset time delay of output relay R4	R4tr			

Commissioning Engineer : \_\_\_\_\_

Date : \_\_\_\_\_

Customer Witness : \_\_\_\_\_

Date : \_\_\_\_\_