

# ***PROTECTA Lines***

**E3-Feeder configuration description  
(Type : DTIVA)**



**MICROENER**



**FDE N°: 14JMC1761639 rev1.1**

## User's manual version information

Version	Date	Modification	Compiled by
	17. 10. 2011		Petri
	15. 05. 2012	CB1Pol, DisConn, MXU	Kazai, Ferencsik
V1.0	14.04.2013	Modified: 1.1.3 Hardware configuration Added: 2 External connection	Tóth
V1.1	22.06.2014	Minor correction in Chapter	Tóth

---

## CONTENTS

1	Configuration description.....	4
1.1	Application.....	4
1.1.1	Protection functions .....	4
1.1.2	Measurement functions.....	5
1.1.3	Hardware configuration.....	6
1.1.4	The applied hardware modules .....	7
1.2	Meeting the device .....	7
1.3	Software configuration .....	8
1.3.1	Protection functions .....	8
1.3.1.1	Three-phase instantaneous overcurrent protection function (IOC50).....	9
1.3.1.2	Three-phase time overcurrent protection function (TOC51) .....	10
1.3.1.3	Three-phase directional overcurrent protection function (TOC67) .....	13
1.3.1.4	Residual instantaneous overcurrent protection function (IOC50N).....	15
1.3.1.5	Residual overcurrent protection function (TOC51N) .....	16
1.3.1.6	Residual directional overcurrent protection function (TOC67N) .....	19
1.3.1.7	Inrush detection function (INR68).....	22
1.3.1.8	Negative sequence overcurrent protection function (TOC46) .....	24
1.3.1.9	Line thermal protection function (TTR49L).....	27
1.3.1.10	Definite time overvoltage protection function (TOV59) .....	30
1.3.1.11	Definite time undervoltage protection function (TUV27) .....	31
1.3.1.12	Residual definite time overvoltage protection function (TOV59N) .....	32
1.3.1.13	Over-frequency protection function (TOF81).....	33
1.3.1.14	Underfrequency protection function (TUF81) .....	34
1.3.1.15	Rate of change of frequency protection function (FRC81).....	35
1.3.1.16	Synchro check, synchro switch function (SYN25) .....	37
1.3.1.17	Auto-reclose protection (REC79MV).....	40
1.3.1.18	Current unbalance function (VCB60).....	43
1.3.1.19	Breaker failure protection function (BRF50).....	45
1.3.1.20	Directional over-power protection function (DOP32) .....	47
1.3.1.21	Directional under-power protection function (DUP32) .....	48
1.3.1.22	Trip logic (TRC94) .....	49
1.3.1.23	Dead line detection function (DLD) .....	50
1.3.1.24	Current input function (CT4).....	51
1.3.1.25	Voltage input function (VT4) .....	54
1.3.1.26	Circuit breaker control function block (CB1Pol).....	57
1.3.1.27	Disconnecter control function (DisConn).....	60
1.3.1.28	Line measurement function (MXU).....	62
2	External connections .....	68

## 1 Configuration description

The E3-Feeder protection device is a member of the **EuroProt+** product line, made by Protecta Co. Ltd. The **EuroProt+** type complex protection in respect of hardware and software is a modular device. The modules are assembled and configured according to the requirements, and then the software determines the functions. This manual describes the specific application of the E3-Feeder factory configuration.

### 1.1 Application

The members of the DTIVA product line are configured to protect and control the elements of the medium voltage networks.

#### 1.1.1 Protection functions

The E3-Feeder configuration measures three phase currents, the zero sequence current component and additionally three phase voltages and the busbar voltage. These measurements allow, in addition to the current- and voltage-based functions, directionality extension of the configured phase and residual overcurrent function and also directional overpower or underpower functions. It is intended to protect overhead line or cable networks. The choice of the functions is extended with the automatic reclosing function and synchro-check. The configuration is designed to meet the requirements of a medium voltage field unit. Based on the voltage measurement also the frequency is evaluated to realize frequency-based protection functions.

The configured protection functions are listed in the Table below.

Protection functions	IEC	ANSI	E3-Feeder
Three-phase instantaneous overcurrent protection	I >>>	50	X
Three-phase time overcurrent protection	I >, I >>	51	X
Three-phase directional overcurrent protection	I Dir > >, I Dir >>	67	X
Residual instantaneous overcurrent protection	Io >>>	50N	X
Residual time overcurrent protection	Io >, Io >>	51N	X
Residual directional overcurrent protection	Io Dir > >, Io Dir >>	67N	X
Inrush detection and blocking	I <sub>2h</sub> >	68	X
Negative sequence overcurrent protection	I <sub>2</sub> >	46	X
Thermal protection	T >	49	X
Definite time overvoltage protection	U >, U >>	59	X
Definite time undervoltage protection	U <, U <<	27	X
Residual overvoltage protection	U <sub>0</sub> >, U <sub>0</sub> >>	59N	X
Negative sequence overvoltage protection	U <sub>2</sub> >	47	X
Overfrequency protection	f >, f >>	81O	X
Underfrequency protection	f <, f <<	81U	X
Rate of change of frequency protection	df/dt	81R	X
Synchrocheck	SYNC	25	X
Auto-reclose	0 - > 1	79	X
Current unbalance protection		60	X
Breaker failure protection	CBFP	50BF	X
Directional overpower	P >	32	X
Directional underpower	P <	32	X
Busbar sub-unit			Op.

Table 1 The protection functions of the E3-Feeder configuration

The configured functions are drawn symbolically in the Figure below.

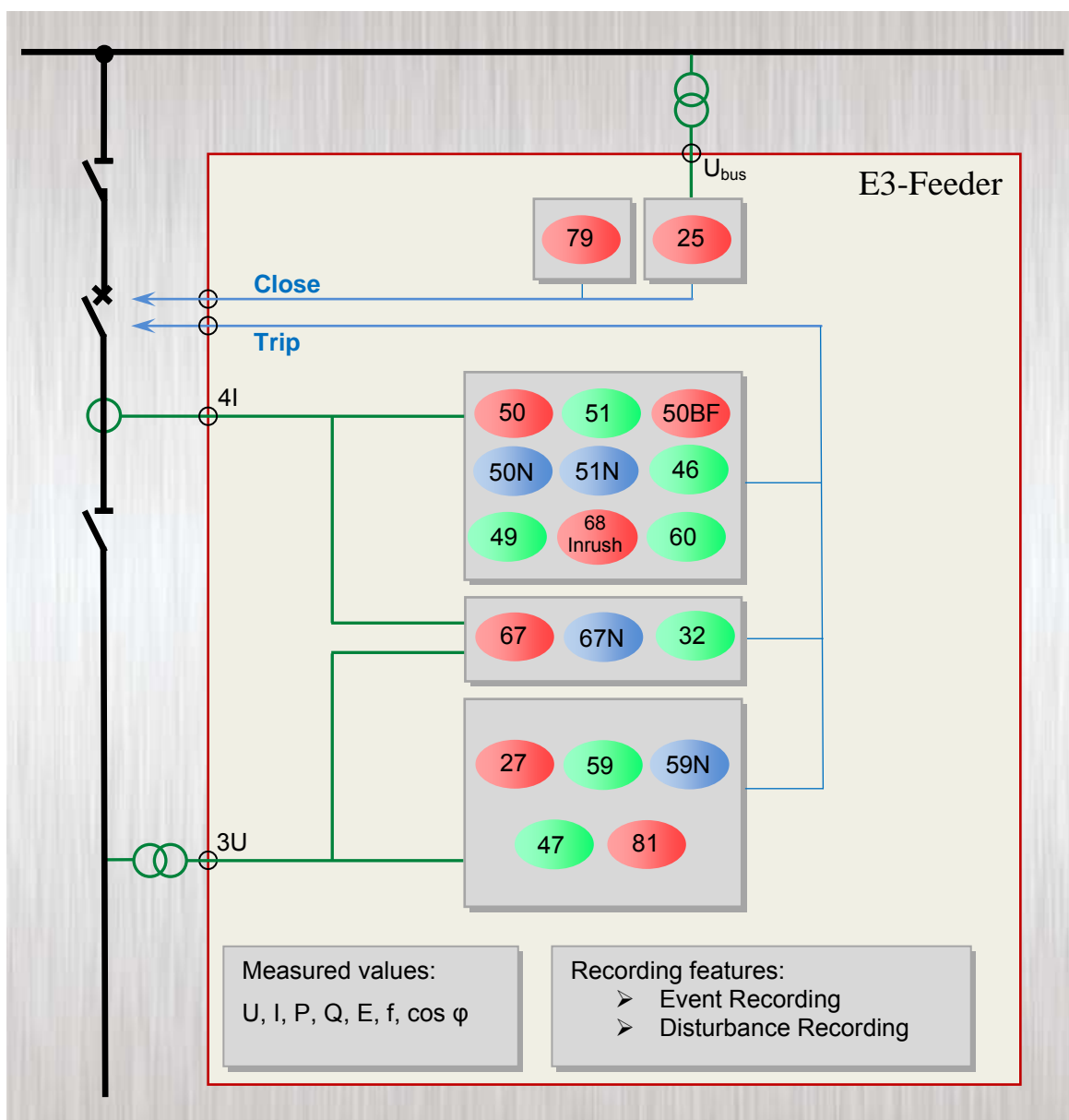

Figure 1 Implemented protection functions

### 1.1.2 Measurement functions

Based on the hardware inputs the measurements listed in Table below are available.

Measurement functions	E3-Feeder
Current (I1, I2, I3, Io)	X
Voltage (U1, U2, U3, U12, U23, U31, Uo, Useq) and frequency	X
Power (P, Q, S, pf) and Energy (E+, E-, Eq+, Eq-)	X
Circuit breaker wear	X
Supervised trip contacts (TCS)	X

Table 2 The measurement functions of the E3-Feeder configuration

### 1.1.3 Hardware configuration

The minimum number of inputs and outputs are listed in the Table below.

Hardware configuration	ANSI	E3-Feeder
Mounting		<b>Op.</b>
Panel instrument case		
Current inputs (4th channel can be sensitive)		<b>4</b>
Voltage inputs		<b>4</b>
Digital inputs		<b>12</b>
Digital outputs		<b>8</b>
Fast trip outputs		<b>2</b>
Temperature monitoring (RTDs) *	38 / 49T	<b>Op.</b>

Table 3 The basic hardware configuration of the E3-Feeder configuration

The basic module arrangement of the E3-Feeder configuration is shown below.

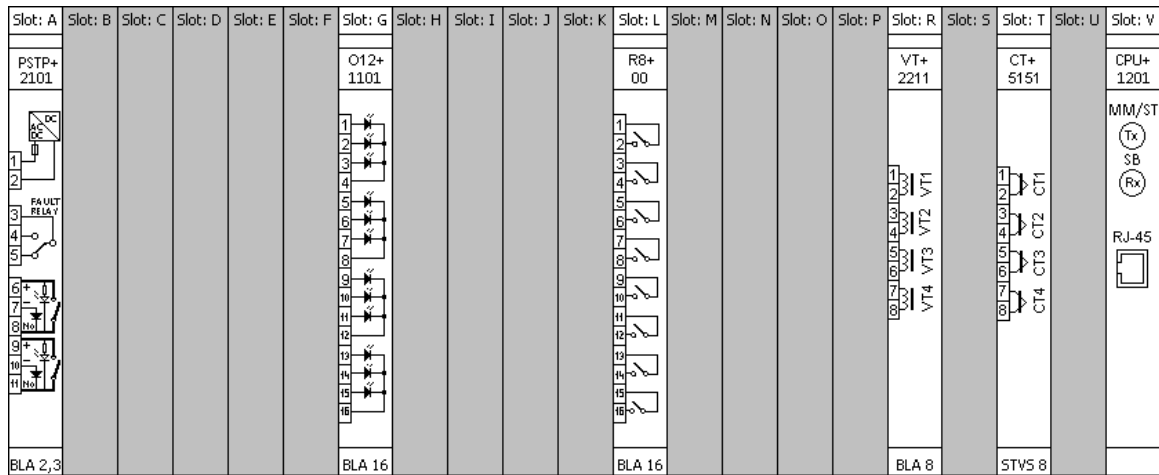

Figure 2 Basic module arrangement of the E3-Feeder configuration (84TE, rear view)

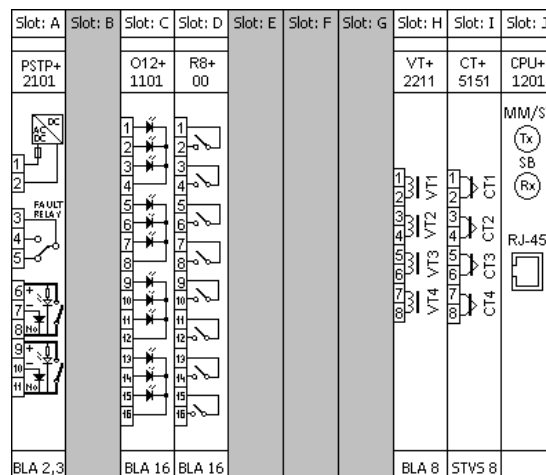

Figure 3 Basic module arrangement of the E3-Feeder configuration (42TE, rear view)

### 1.1.4 The applied hardware modules

The applied modules are listed in Table 4.

The technical specification of the device and that of the modules are described in the document “**Hardware description**”.

Module identifier	Explanation
PSTP+ 2101	Power supply unit
O12+ 1101	Binary input module
R8+ 00	Signal relay output module
VT+ 2211	Analog voltage input module
CT + 5151	Analog current input module
CPU+ 1201	Processing and communication module

*Table 4 The applied modules of the E3-Feeder configuration*

## 1.2 Meeting the device

The basic information for working with the **EuroProt+** devices are described in the document “**Quick start guide to the devices of the EuroProt+ product line**”.



*Figure 4 The 84 inch rack of EuroProt+ family*



*Figure 5 The 42 inch rack of EuroProt+ family*

## 1.3 Software configuration

### 1.3.1 Protection functions

The implemented protection functions are listed in Table 5. The function blocks are described in details in separate documents. These are referred to also in this table.

Name	Title	Document
IOC50	3ph Instant.OC	<b><i>Three-phase instantaneous overcurrent protection function block description</i></b>
TOC51_low TOC51_high	3ph Overcurr	<b><i>Three-phase overcurrent protection function block description</i></b>
TOC67_low TOC67_high	3ph Dir.Overcurr	<b><i>Directional three-phase overcurrent protection function block description</i></b>
IOC50N	Residual Instant.OC	<b><i>Residual instantaneous overcurrent protection function block description</i></b>
TOC51N_low TOC51N_high	Residual TOC	<b><i>Residual overcurrent protection function block description</i></b>
TOC67N_low TOC67N_high	Dir.Residual TOC	<b><i>Directional residual overcurrent protection function block description</i></b>
INR68	Inrush	<b><i>Inrush detection and blocking protection function block description</i></b>
TOC46	Neg. Seq. OC	<b><i>Negative sequence overcurrent protection function block description</i></b>
TTR49L	Thermal overload	<b><i>Line thermal protection function block description</i></b>
TOV59_high TOV59_low	Overvoltage	<b><i>Definite time overvoltage protection function block description</i></b>
TUV27_high TUV27_low	Undervoltage	<b><i>Definite time undervoltage protection function block description</i></b>
TOV59N_high TOV59N_low	Overvoltage	<b><i>Definite time zero sequence overvoltage protection function block description</i></b>
TOF81_high TOF81_low	Overfrequency	<b><i>Overfrequency protection function block description</i></b>
TUF81_high TUF81_low	Underfrequency	<b><i>Underfrequency protection function block description</i></b>
FRC81	ROC of frequency	<b><i>Rate of change of frequency protection function block description</i></b>
SYN25	Synchrocheck	<b><i>Synchro-check, synchro switch function block description</i></b>
REC79MV	MV autoreclosing	<b><i>Automatic reclosing function for medium voltage networks, function block description</i></b>
VCB60	Current Unbalance	<b><i>Current unbalance function block description</i></b>
BRF50	Breaker failure	<b><i>Breaker failure protection function block description</i></b>
DOP32	Directional OP	<b><i>Directional overpower protection function block description</i></b>
DUP32	Directional UP	<b><i>Directional underpower protection function block description</i></b>
TRC94	Trip Logic	<b><i>Trip logic function block description</i></b>
CT4		<b><i>Current input function block description</i></b>
VT4		<b><i>Voltage input function block description</i></b>
CB1Pol		<b><i>Circuit breaker control function block description</i></b>
DisConn		<b><i>Disconnecter control function block description</i></b>
MXU		<b><i>Line measurement function block description</i></b>

*Table 5 Implemented protection functions*



### 1.3.1.1 Three-phase instantaneous overcurrent protection function (IOC50)

The three-phase instantaneous overcurrent protection function (IOC50) operates immediately if the phase currents are higher than the setting value.

The setting value is a parameter, and it can be doubled by graphic programming of the dedicated input binary signal defined by the user.

The function is based on peak value selection or on the RMS values of the Fourier basic harmonic calculation, according to the parameter setting. The fundamental Fourier components are results of an external function block.

Parameter for type selection has selection range of Off, Peak value and Fundamental value. When Fourier calculation is selected then the accuracy of the operation is high, the operation time however is above one period of the network frequency. If the operation is based on peak values then fast sub-cycle operation can be expected, but the transient overreach can be high.

The function generates trip commands without additional time delay if the detected values are above the current setting value.

The function generates trip commands for the three phases individually and a general trip command as well.

The instantaneous overcurrent protection function has a binary input signal, which serves the purpose of disabling the function. The conditions of disabling are defined by the user, applying the graphic equation editor.

#### Technical data

Function		Accuracy
<b>Using peak value calculation</b>		
Operating characteristic	Instantaneous	<6%
Reset ratio	0.85	
Operate time at $2 \cdot I_s$	<15 ms	
Reset time *	< 40 ms	
Transient overreach	90 %	
<b>Using Fourier basic harmonic calculation</b>		
Operating characteristic	Instantaneous	<2%
Reset ratio	0.85	
Operate time at $2 \cdot I_s$	<25 ms	
Reset time *	< 60 ms	
Transient overreach	15 %	

\*Measured with signal contacts

Table 6 Technical data of of the instantaneous overcurrent protection function

#### Parameters

##### Enumerated parameter

Parameter name	Title	Selection range	Default
Parameter for type selection			
IOC50_Oper_EPar_	Operation	Off, Peak value, Fundamental value	Peak value

Table 7 The enumerated parameter of the instantaneous overcurrent protection function

##### Integer parameter

Parameter name	Title	Unit	Min	Max	Step	Default
Starting current parameter:						
IOC50_StCurr_IPar_	Start Current	%	20	3000	1	200

Table 8 The integer parameter of the instantaneous overcurrent protection function

### 1.3.1.2 Three-phase time overcurrent protection function (TOC51)

The overcurrent protection function realizes definite time or inverse time characteristics according to IEC or IEEE standards, based on three phase currents. The characteristics are harmonized with IEC 60255-151, Edition 1.0, 2009-08. This function can be applied as main protection for medium-voltage applications or backup or overload protection for high-voltage network elements.

The definite (independent) time characteristic has a fixed time delay when the current is above the starting current  $I_s$  previously set as a parameter.

The standard operating characteristics of the inverse time overcurrent protection function are defined by the following formula:

$$t(G) = TMS \left[ \frac{k}{\left(\frac{G}{G_s}\right)^\alpha - 1} + c \right] \text{ when } G > G_s$$

where

$t(G)$ (seconds)

$k, c$

$\alpha$

$G$

$G_s$

$TMS$

theoretical operate time with constant value of  $G$ ,  
 constants characterizing the selected curve (in seconds),  
 constants characterizing the selected curve (no dimension),  
 measured value of the characteristic quantity, Fourier base harmonic  
 of the phase currents (IL1Four, IL2Four, IL3Four),  
 preset value of the characteristic quantity (Start current),  
 preset time multiplier (no dimension).

	IEC ref	Title	$k_r$	$c$	$\alpha$
1	A	IEC Inv	0,14	0	0,02
2	B	IEC VeryInv	13,5	0	1
3	C	IEC ExtInv	80	0	2
4		IEC LongInv	120	0	1
5		ANSI Inv	0,0086	0,0185	0,02
6	D	ANSI ModInv	0,0515	0,1140	0,02
7	E	ANSI VeryInv	19,61	0,491	2
8	F	ANSI ExtInv	28,2	0,1217	2
9		ANSI LongInv	0,086	0,185	0,02
10		ANSI LongVeryInv	28,55	0,712	2
11		ANSI LongExtInv	64,07	0,250	2

The end of the effective range of the dependent time characteristics ( $G_D$ ) is:

$$G_D = 20 * G_s$$

Above this value the theoretical operating time is definite:

$$t(G) = TMS \left[ \frac{k}{\left(\frac{G_D}{G_s}\right)^\alpha - 1} + c \right] \text{ when } G > G_D = 20 * G_s$$

Additionally a minimum time delay can be defined by a dedicated parameter. This delay is valid if it is longer than  $t(G)$ , defined by the formula above.

Resetting characteristics:

- for IEC type characteristics the resetting is after a fix time delay defined by TOC51\_Reset\_TPar\_ (Reset delay),
- for ANSI types however according to the formula below:

$$t_r(G) = TMS \left[ \frac{k_r}{1 - \left(\frac{G}{G_s}\right)^\alpha} \right] \text{ when } G < G_s$$

where

$t_r(G)$ (seconds)

$k_r$

$\alpha$

$G$

$G_s$

TMS

theoretical reset time with constant value of  $G$ ,  
 constants characterizing the selected curve (in seconds),  
 constants characterizing the selected curve (no dimension),  
 measured value of the characteristic quantity, Fourier base harmonic  
 of the phase currents,  
 preset value of the characteristic quantity (Start current),  
 preset time multiplier (no dimension).

	IEC ref	Title	$k_r$	$\alpha$
1	A	IEC Inv	Resetting after fix time delay, according to preset parameter TOC51_Reset_TPar_ "Reset delay"	
2	B	IEC VeryInv		
3	C	IEC ExtInv		
4		IEC LongInv		
5		ANSI Inv	0,46	2
6	D	ANSI ModInv	4,85	2
7	E	ANSI VeryInv	21,6	2
8	F	ANSI ExtInv	29,1	2
9		ANSI LongInv	4,6	2
10		ANSI LongVeryInv	13,46	2
11		ANSI LongExtInv	30	2

The binary output status signals of the three-phase overcurrent protection function are starting signals of the three phases individually, a general starting signal and a general trip command.

The overcurrent protection function has a binary input signal, which serves the purpose of disabling the function. The conditions of disabling are defined by the user, applying the graphic equation editor.

**Technical data**

Function	Value	Accuracy
Operating accuracy	$20 \leq G_s \leq 1000$	< 2 %
Operate time accuracy		$\pm 5\%$ or $\pm 15$ ms, whichever is greater
Reset ratio	0,95	
Reset time * Dependent time char. Definite time char.	Approx 60 ms	< 2% or $\pm 35$ ms, whichever is greater
Transient overreach		< 2 %
Pickup time *	< 40 ms	
Overshot time Dependent time char. Definite time char.	30 ms 50 ms	
Influence of time varying value of the input current (IEC 60255-151)		< 4 %

\* Measured with signal relay contact

Table 9 Technical data of of the instantaneous overcurrent protection function

**Parameters****Enumerated parameters**

Parameter name	Title	Selection range	Default
Parameter for type selection			
TOC51_Oper_EPar_	Operation	Off, DefinitTime, IEC Inv, IEC VeryInv, IEC ExtInv, IEC LongInv, ANSI Inv, ANSI ModInv, ANSI VeryInv, ANSI ExtInv, ANSI LongInv, ANSI LongVeryInv, ANSI LongExtInv	Definit Time

Table 10 The enumerated parameters of the time overcurrent protection function

**Integer parameter**

Parameter name	Title	Unit	Min	Max	Step	Default
Starting current parameter:						
TOC51_StCurr_IPar_	Start Current	%	20	1000	1	200

Table 11 The integer parameter of the time overcurrent protection function

**Float point parameter**

Parameter name	Title	Unit	Min	Max	Step	Default
Time multiplier of the inverse characteristics (OC module)						
TOC51_Multip_FPar_	Time Multiplier	sec	0.05	999	0.01	1.0

Table 12 The float point parameter of the time overcurrent protection function

**Timer parameters**

Parameter name	Title	Unit	Min	Max	Step	Default
Minimal time delay for the inverse characteristics:						
TOC51_MinDel_TPar_	Min Time Delay *	msec	0	60000	1	100
Definite time delay:						
TOC51_DefDel_TPar_	Definite Time Delay **	msec	0	60000	1	100
Reset time delay for the inverse characteristics:						
TOC51_Reset_TPar_	Reset Time*	msec	0	60000	1	100

\*Valid for inverse type characteristics

\*\*Valid for definite type characteristics only

Table 13 The timer parameters of the time overcurrent protection function

### 1.3.1.3 Three-phase directional overcurrent protection function (TOC67)

The directional three-phase delayed overcurrent protection function can be applied on solidly grounded networks, where the overcurrent protection must be supplemented with a directional decision.

The inputs of the function are the Fourier basic harmonic components of the three phase currents and those of the three phase voltages and the three line-to-line voltages.

Based on the measured voltages and currents from among the six loops (L1L2, L2L3, L3L1, L1N, L2N, L3N), the function selects the one with the smallest calculated loop impedance. Based on the loop voltage and loop current of the selected loop, the directional decision generates a signal of TRUE value if the voltage and the current is sufficient for directional decision, and the angle difference between the vectors is within the setting range. This decision enables the output start and trip signal of a non-directional three-phase overcurrent protection function block, based on the selected current.

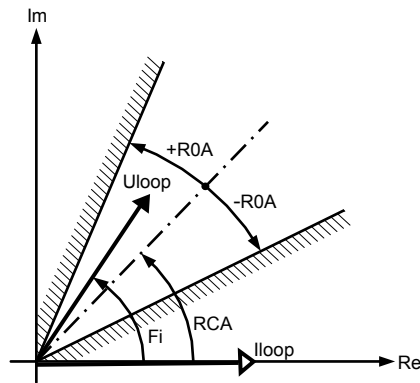

The function can be enabled or disabled by a parameter. The status signal of the VTS (voltage transformer supervision) function can also disable the directional operation.

The voltage must be above 5% of the rated voltage and the current must also be measurable.

If the voltages are below 5% of the rated voltage then the algorithm substitutes the small values with the voltages stored in the memory.

The directional decision module calculates the phase angle between the selected loop voltage and the loop current. The reference signal is the current according to *Figure*.

The three-phase non-directional delayed overcurrent function block (TOC51) is described in a separate document. The additional input binary signal enables the operation of the OC function if the directional decision module generates a logic TRUE value, indicating that the phase angle is in the range defined by the preset parameters or that non-directional operation is set by a parameter.

#### Technical data

Function	Value	Accuracy
Operating accuracy		< 2 %
Operate time accuracy	If Time multiplier is >0.1	±5% or ±15 ms, whichever is greater
Accuracy in minimum time range		±35 ms
Reset ratio	0,95	
Reset time	Approx 100 ms	
Transient overreach	2 %	
Pickup time	<100 ms	
Memory storage time span		
50 Hz	70 ms	
60 Hz	60 ms	
Angular accuracy		<3°

Table 14 Technical data of the three-phase directional overcurrent protection function

**Parameters****Enumerated parameters**

Parameter name	Title	Selection range	Default
Directionality of the function			
TOC67_Dir_EPar_	Direction	NonDir, Forward, Backward	Forward
Operating characteristic selection of the TOC51 module			
TOC67_Oper_EPar_	Operation	Off, DefiniteTime, IEC Inv, IEC VeryInv, IEC ExtInv, IEC LongInv, ANSI Inv, ANSI ModInv, ANSI VeryInv, ANSI ExtInv, ANSI LongInv, ANSI LongVeryInv, ANSI LongExtInv	DefiniteTime

*Table 15 The enumerated parameters of the three-phase directional overcurrent protection function*

**Integer parameters**

Parameter name	Title	Unit	Min	Max	Step	Default
Operating angle (see <i>Figure</i> )						
TOC67_ROA_IPar_	Operating Angle	deg	30	80	1	60
Characteristic angle (see <i>Figure</i> )						
TOC67_RCA_IPar_	Characteristic Angle	deg	40	90	1	60
Start current (OC module)						
TOC67_StCurr_IPar_	Start Current	%	20	1000	1	50

*Table 16 The integer parameters of the three-phase directional overcurrent protection function*

**Float point parameter**

Parameter name	Title	Unit	Min	Max	Digits	Default
Time multiplier of the inverse characteristics (OC module)						
TOC67_Multip_FPar_	Time Multiplier	sec	0.05	999	-2	1.0

*Table 17 The float point parameter of the three-phase directional overcurrent protection function*

**Timer parameters**

Parameter name	Title	Unit	Min	Max	Step	Default
Minimal time delay for the inverse characteristics (OC module):						
TOC67_MinDel_TPar_	Min. Time	msec	50	60000	1	100
Definite time delay (OC module):						
TOC67_DefDel_TPar_	Definite Time	msec	0	60000	1	100
Reset time delay for the inverse characteristics (OC module):						
TOC67_Reset_TPar_	Reset Time	msec	0	60000	1	100

*Table 18 The timer parameters of the three-phase directional overcurrent protection function*

### 1.3.1.4 Residual instantaneous overcurrent protection function (IOC50N)

The residual instantaneous overcurrent protection function (IOC50N) block operates immediately if the residual current ( $3I_0$ ) is above the setting value. The setting value is a parameter, and it can be doubled by a dedicated binary input signal defined by the user applying the graphic programming.

The function is based on peak value selection or on the RMS values of the Fourier basic harmonic component of the residual current, according to the parameter setting. The fundamental Fourier component calculation is not part of the IOC50N function.

Parameter for type selection has selection range of Off, Peak value and Fundamental value.

The function generates a trip commands without additional time delay if the detected values are above the current setting value.

The residual instantaneous overcurrent protection function has a binary input signal, which serves the purpose of disabling the function. The conditions of disabling are defined by the user, applying the graphic equation editor.

#### Technical data

Function		Accuracy
<b>Using peak value calculation</b>		
Operating characteristic ( $I > 0.1 I_n$ )	Instantaneous	<6%
Reset ratio	0.85	
Operate time at $2 \cdot I_s$	<15 ms	
Reset time *	< 35 ms	
Transient overreach	85 %	
<b>Using Fourier basic harmonic calculation</b>		
Operating characteristic ( $I > 0.1 I_n$ )	Instantaneous	<3%
Reset ratio	0.85	
Operate time at $2 \cdot I_s$	<25 ms	
Reset time *	< 60 ms	
Transient overreach	15 %	

\*Measured with signal contacts

Table 19 Technical data of the residual instantaneous overcurrent protection function

#### Parameters

##### Enumerated parameter

Parameter name	Title	Selection range	Default
Parameter for type selection			
IOC50N_Oper_EPar_	Operation	Off, Peak value, Fundamental value	Peak value

Table 20 The enumerated parameter of the residual instantaneous overcurrent protection function

##### Integer parameter

Parameter name	Title	Unit	Min	Max	Step	Default
Starting current parameter:						
IOC50N_StCurr_IPar_	Start Current	%	10	400	1	200

Table 21 The integer parameter of the residual instantaneous overcurrent protection function

### 1.3.1.5 Residual overcurrent protection function (TOC51N)

The residual delayed overcurrent protection function can realize definite time or inverse time characteristics according to IEC or IEEE standards, based on the RMS value of the fundamental Fourier component of a single measured current, which can be the measured residual current at the neutral point (3I<sub>0</sub>) or the calculated zero sequence current component. The characteristics are harmonized with IEC 60255-151, Edition 1.0, 2009-08.

The definite (independent) time characteristic has a fixed time delay when the current is above the starting current I<sub>s</sub> previously set as a parameter.

The standard operating characteristics of the inverse time overcurrent protection function are defined by the following formula:

$$t(G) = TMS \left[ \frac{k}{\left(\frac{G}{G_s}\right)^\alpha - 1} + c \right] \text{ when } G > G_s$$

where

t(G)(seconds)

k, c

α

G

G<sub>s</sub>

TMS

theoretical operate time with constant value of G,  
constants characterizing the selected curve (in seconds),  
constant characterizing the selected curve (no dimension),  
measured value of the characteristic quantity, Fourier base harmonic  
of the residual current (INFour),  
preset value of the characteristic quantity (Start current),  
preset time multiplier (no dimension).

	IEC ref		k <sub>r</sub>	c	α
1	A	IEC Inv	0,14	0	0,02
2	B	IEC VeryInv	13,5	0	1
3	C	IEC ExtInv	80	0	2
4		IEC LongInv	120	0	1
5		ANSI Inv	0,0086	0,0185	0,02
6	D	ANSI ModInv	0,0515	0,1140	0,02
7	E	ANSI VeryInv	19,61	0,491	2
8	F	ANSI ExtInv	28,2	0,1217	2
9		ANSI LongInv	0,086	0,185	0,02
10		ANSI LongVeryInv	28,55	0,712	2
11		ANSI LongExtInv	64,07	0,250	2

The end of the effective range of the dependent time characteristics (G<sub>D</sub>) is:

$$G_D = 20 * G_s$$

Above this value the theoretical operating time is definite:

$$t(G) = TMS \left[ \frac{k}{\left(\frac{G_D}{G_s}\right)^\alpha - 1} + c \right] \text{ when } G > G_D = 20 * G_s$$

Additionally a minimum time delay can be defined by a dedicated parameter (Min. Time Delay). This delay is valid if it is longer than t(G), defined by the formula above.

Resetting characteristics:

- for IEC type characteristics the resetting is after a fix time delay,
- for ANSI types however according to the formula below:



$$t_r(G) = TMS \left[ \frac{k_r}{1 - \left(\frac{G}{G_S}\right)^\alpha} \right] \text{ when } G < G_S$$

where

$t_r(G)$ (seconds)

$k_r$

$\alpha$

$G$

$G_S$

TMS

theoretical reset time with constant value of  $G$ ,  
 constants characterizing the selected curve (in seconds),  
 constant characterizing the selected curve (no dimension),  
 measured value of the characteristic quantity, Fourier base harmonic  
 of the residual current,  
 preset value of the characteristic quantity (Start current),  
 preset time multiplier (no dimension).

	IEC ref		$k_r$	$\alpha$
1	A	IEC Inv	Resetting after fix time delay, according to preset parameter TOC51_Reset_TPar_ "Reset delay"	
2	B	IEC VeryInv		
3	C	IEC ExtInv		
4		IEC LongInv		
5		ANSI Inv	0,46	2
6	D	ANSI ModInv	4,85	2
7	E	ANSI VeryInv	21,6	2
8	F	ANSI ExtInv	29,1	2
9		ANSI LongInv	4,6	2
10		ANSI LongVeryInv	13,46	2
11		ANSI LongExtInv	30	2

The binary output status signals of the residual overcurrent protection function are the general starting signal and the general trip command if the time delay determined by the characteristics expired.

The residual overcurrent protection function has a binary input signal, which serves the purpose of disabling the function. The conditions of disabling are defined by the user, applying the graphic equation editor.

### Technical data

Function	Value	Accuracy
Operating accuracy *	$20 \leq G_S \leq 1000$	< 3 %
Operate time accuracy		$\pm 5\%$ or $\pm 15$ ms, whichever is greater
Reset ratio	0,95	
Reset time * Dependent time char. Definite time char.	Approx 60 ms	< 2% or $\pm 35$ ms, whichever is greater
Transient overreach		2 %
Pickup time	$\leq 40$ ms	
Overshot time Dependent time char. Definite time char.	30 ms 50 ms	
Influence of time varying value of the input current (IEC 60255-151)		< 4 %

\* Measured in version  $I_n = 200$  mA

Table 22 The technical data of the residual overcurrent protection function

**Parameters****Enumerated parameters**

Parameter name	Title	Selection range	Default
Parameter for type selection			
TOC51N_Oper_EPar_	Operation	Off, DefinitTime, IEC Inv, IEC VeryInv, IEC ExtInv, IEC LongInv, ANSI Inv, ANSI ModInv, ANSI VeryInv, ANSI ExtInv, ANSI LongInv, ANSI LongVeryInv, ANSI LongExtInv	Definite Time

Table 23 The enumerated parameters of the residual overcurrent protection function

**Integer parameter**

Parameter name	Title	Unit	Min	Max	Step	Default
Starting current parameter:						
TOC51N_StCurr_IPar_	Start Current *	%	5	200	1	50
TOC51N_StCurr_IPar_	Start Current **	%	10	1000	1	50

\*  $I_n = 1\text{ A or }5\text{ A}$

\*\*  $I_n = 200\text{ mA or }1\text{ A}$

Table 24 The integer parameter of the residual overcurrent protection function

**Float point parameter**

Parameter name	Title	Unit	Min	Max	Step	Default
Time multiplier of the inverse characteristics (OC module)						
TOC51N_Multip_FPar_	Time Multiplier	sec	0.05	999	0.01	1.0

Table 25 The float parameter of the residual overcurrent protection function

**Timer parameters**

Parameter name	Title	Unit	Min	Max	Step	Default
Minimal time delay for the inverse characteristics:						
TOC51N_MinDel_TPar_	Min Time Delay*	msec	0	60000	1	100
Definite time delay:						
TOC51N_DefDel_TPar_	Definite Time Delay**	msec	0	60000	1	100
Reset time delay for the inverse characteristics:						
TOC51N_Reset_TPar_	Reset Time*	msec	0	60000	1	100

\*Valid for inverse type characteristics

\*\*Valid for definite type characteristics only

Table 26 The timer parameters of the residual overcurrent protection function

### 1.3.1.6 Residual directional overcurrent protection function (TOC67N)

The main application area of the directional residual delayed overcurrent protection function is an earth-fault protection.

The inputs of the function are the RMS value of the Fourier basic harmonic components of the zero sequence current ( $I_N=3I_0$ ) and those of the zero sequence voltage ( $U_N=3U_0$ ).

The block of the directional decision generates a signal of TRUE value if the  $U_N=3U_0$  zero

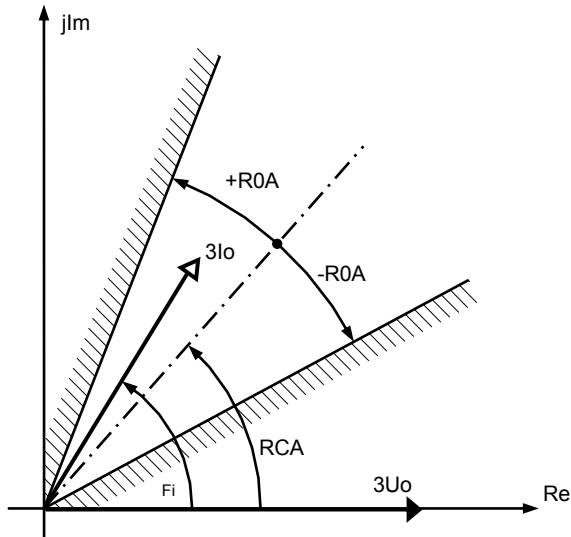

sequence voltage and the  $I_N=3I_0$  zero sequence current are above the limits needed for correct directional decision, and the angle difference between the vectors is within the preset range. The decision enables the output start and trip signal of an overcurrent protection function block (TOC51N). This non-directional residual overcurrent protection function block is described in a separate document.

The directional decision module calculates the phase angle between the residual voltage and the residual current. The reference signal is the residual voltage according to the *Figure*.

The output of the directional decision module is OK, namely it is TRUE if the phase angle between the residual voltage and the residual current is within the limit range defined by the preset parameter OR if non-directional operation is selected by the preset parameter (Direction=NonDir).

#### Technical data

Function	Value	Accuracy
Operating accuracy		< $\pm 2\%$
Operate time accuracy		$\pm 5\%$ or $\pm 15$ ms, whichever is greater
Accuracy in minimum time range		$\pm 35$ ms
Reset ratio	0,95	
Reset time	Approx 50 ms	$\pm 35$ ms
Transient overreach	<2 %	
Pickup time	25 – 30 ms	
Angular accuracy		
$I_0 \leq 0.1 I_n$		< $\pm 10^\circ$
$0.1 I_n < I_0 \leq 0.4 I_n$		< $\pm 5^\circ$
$0.4 I_n < I_0$		< $\pm 2^\circ$
Angular reset ratio		
Forward and backward	10°	
All other selection	5°	

Table 27 The technical data of the residual directional overcurrent protection function

**Parameters****Enumerated parameters**

Parameter name	Title	Selection range	Default
Directionality of the function			
TOC67N_Dir_EPar_	Direction	NonDir,Forward-Angle,Backward-Angle,Forward-I*cos(fi),Backward-I*cos(fi),Forward-I*sin(fi),Backward-I*sin(fi),Forward-I*sin(fi+45),Backward-I*sin(fi+45)	Forward-Angle
Operating characteristic selection of the TOC51N module			
TOC67N_Oper_EPar_	Operation	Off,DefiniteTime,IEC Inv,IEC VeryInv,IEC ExtInv,IEC LongInv,ANSI Inv,ANSI ModInv,ANSI VeryInv,ANSI ExtInv,ANSI LongInv,ANSI LongVeryInv,ANSI LongExtInv	DefiniteTime

*Table 28 The enumerated parameters of the residual directional overcurrent protection function*

**Short explanation of the enumerated parameter “Direction”**

Selected value	Explanation
NonDir,	Operation according to non-directional TOC51N
Forward-Angle	See <i>Figure</i> , set RCA (Characteristic Angle) and ROA (Operating Angle) as required
Backward-Angle	$RCA_{actual}=RCA_{set}+180^\circ$ , set RCA (Characteristic Angle) and ROA (Operating Angle) as required
Forward-I*cos(fi)	$RCA=0^\circ$ fix, $ROA=85^\circ$ fix, the setting values RCA and ROA are not applied
Backward-I*cos(fi)	$RCA=180^\circ$ fix, $ROA=85^\circ$ fix, the setting values RCA and ROA are not applied
Forward-I*sin(fi)	$RCA=90^\circ$ fix, $ROA=85^\circ$ fix, the setting values RCA and ROA are not applied
Backward-I*sin(fi)	$RCA=-90^\circ$ fix, $ROA=85^\circ$ fix, the setting values RCA and ROA are not applied
Forward-I*sin(fi+45)	$RCA=45^\circ$ fix, $ROA=85^\circ$ fix, the setting values RCA and ROA are not applied
Backward-I*sin(fi+45)	$RCA=-135^\circ$ fix, $ROA=85^\circ$ fix, the setting values RCA and ROA are not applied

*Table 29 The short explanation of the enumerated parameters of the residual directional overcurrent protection function*

**Integer parameters**

Parameter name	Title	Unit	Min	Max	Step	Default
The threshold value for the 3U <sub>0</sub> zero sequence voltage, below which no directionality is possible. % of the rated voltage of the voltage transformer input						
TOC67N_UoMin_IPar_	URes Min	%	1	10	1	2
The threshold value for the 3I <sub>0</sub> zero sequence current, below which no operation is possible. % of the rated current of the current transformer input						
TOC67N_IoMin_IPar_	IRes Min	%	1	50	1	5
Operating angle (See <i>Figure</i> )						
TOC67N_ROA_IPar_	Operating Angle	deg	30	80	1	60
Characteristic angle (See <i>Figure</i> )						
TOC67N_RCA_IPar_	Characteristic Angle	deg	-180	180	1	60
Start current (TOC51N module)						
TOC67N_StCurr_IPar_	Start Current	%	5	200	1	50

*Table 30 The integer parameters of the residual directional overcurrent protection function*

**Float point parameter**

Parameter name	Title	Unit	Min	Step	Step	Default
Time multiplier of the inverse characteristics (TOC51N module)						
TOC67N_Multip_FPar_	Time Multiplier	sec	0.05	999	0.01	1.0

*Table 31 The float point parameter of the residual directional overcurrent protection function*

**Timer parameters**

Parameter name	Title	Unit	Min	Max	Step	Default
Minimal time delay for the inverse characteristics (TOC 51N module):						
TOC67N_MinDel_TPar_	Min Time Delay	msec	50	60000	1	100
Definite time delay (TOC 51N module):						
TOC67N_DefDel_TPar_	Definite Time Delay	msec	0	60000	1	100
Reset time delay for the inverse characteristics (TOC 51N module):						
TOC67N_Reset_TPar_	Reset Time	msec	0	60000	1	100

*Table 32 The timer parameters of the residual directional overcurrent protection function*

### 1.3.1.7 Inrush detection function (INR68)

When an inductive element with an iron core (transformer, reactor, etc.) is energized, high current peak values can be detected. This is caused by the transient asymmetric saturation of the iron core as a nonlinear element in the power network. The sizing of the iron core is usually sufficient to keep the steady state magnetic flux values below the saturation point of the iron core, so the inrush transient slowly dies out. These current peaks depend also on random factors such as the phase angle at energizing. Depending on the shape of the magnetization curve of the iron core, the detected peaks can be several times above the rated current peaks. Additionally, in medium or high voltage networks, where losses and damping are low, the indicated high current values may be sustained at length. Figure below shows a typical example for the inrush current shapes of a three-phase transformer.

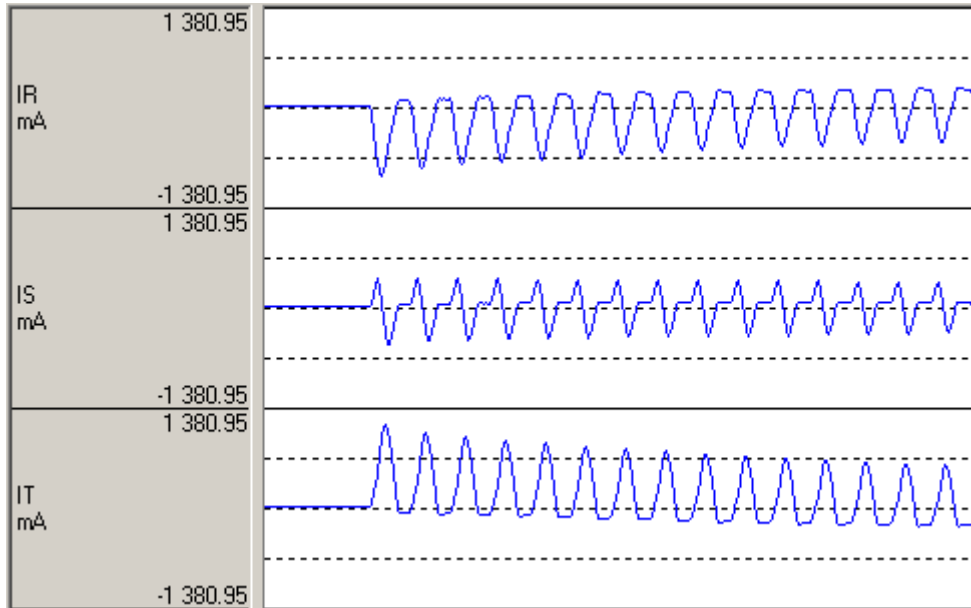

*A typical inrush current*

As a consequence, overcurrent relays, differential relays or distance relays may start, and because of the long duration of the high current peaks, they may generate an unwanted trip command.

The inrush current detection function can distinguish between high currents caused by overload or faults and the high currents during the inrush time.

The operating principle of the inrush current detection function is based on the special shape of the inrush current.

The typical inrush current in one or two phases is asymmetrical to the time axis. For example, in IT of the Figure above the positive peaks are high while no peaks can be detected in the negative domain.

The theory of the Fourier analysis states that even harmonic components (2<sup>nd</sup>, 4<sup>th</sup> etc.) are dominant in waves asymmetrical to the time axis. The component with the highest value is the second one.

Typical overload and fault currents do not contain high even harmonic components.

The inrush current detection function processes the Fourier basic harmonic component and the second harmonic component of the three phase currents. If the ratio of the second harmonic and the base Fourier harmonic is above the setting value of the parameter *2nd Harm Ratio*, an inrush detection signal is generated.

The signal is output only if the base harmonic component is above the level defined by the setting of the parameter *IPh Base Sens*. This prevents unwanted operation in the event that low currents contain relatively high error signals.

The function operates independently using all three phase currents individually, and additionally, a general inrush detection signal is generated if any of the phases detects inrush current.

The function can be disabled by the binary input *Disable*. This signal is the result of logic equations graphically edited by the user.

Using the inrush detection binary signals, other protection functions can be blocked during the transient period so as to avoid the unwanted trip.

Some protection functions use these signals automatically, but a stand-alone inrush detection function block is also available for application at the user's discretion.

### Technical data

Function	Range	Accuracy
Current accuracy	20 ... 2000% of In	±1% of In

Table 33 Technical data of the inrush detection function

### Parameters

#### Enumerated parameter

Parameter name	Title	Selection range	Default
Disabling or enabling the operation of the function			
INR2_Op_EPar_	Operation	Off,On	On

Table 34 The enumerated parameter of the inrush detection function

#### Integer parameters

Parameter name	Title	Unit	Min	Max	Step	Default
Ratio of the second and basic harmonic Fourier components						
INR2_2HRat_IPar_	2nd Harm Ratio	%	5	50	1	15
Basic sensitivity of the function						
INR2_MinCurr_IPar_	IPh Base Sens	%	20	100	1	30

Table 35 The integer parameter of the inrush detection function

### 1.3.1.8 Negative sequence overcurrent protection function (TOC46)

The negative sequence overcurrent protection function (TOC46) block operates if the negative sequence current is higher than the preset starting value.

In the negative sequence overcurrent protection function, definite-time or inverse-time characteristics are implemented, according to IEC or IEEE standards. The function evaluates a single measured current, which is the RMS value of the fundamental Fourier component of the negative sequence current. The characteristics are harmonized with IEC 60255-151, Edition 1.0, 2009-08.

The definite (independent) time characteristic has a fixed delaying time when the current is above the starting current  $G_s$  previously set as a parameter.

The standard dependent time characteristics of the negative sequence overcurrent protection function are as follows.

$$t(G) = TMS \left[ \frac{k}{\left( \frac{G}{G_s} \right)^\alpha - 1} + c \right] \text{ when } G > G_s$$

where

$t(G)$ (seconds)

$k, c$

$\alpha$

$G$

$G_s$

TMS

theoretical operate time with constant value of  $G$ ,  
 constants characterizing the selected curve (in seconds),  
 constant characterizing the selected curve (no dimension),  
 measured value of the characteristic quantity, Fourier base harmonic  
 of the negative sequence current (INFour),  
 preset starting value of the characteristic quantity,  
 preset time multiplier (no dimension).

	IEC ref		$k_r$	$c$	$\alpha$
1	A	IEC Inv	0,14	0	0,02
2	B	IEC VeryInv	13,5	0	1
3	C	IEC ExtInv	80	0	2
4		IEC LongInv	120	0	1
5		ANSI Inv	0,0086	0,0185	0,02
6	D	ANSI ModInv	0,0515	0,1140	0,02
7	E	ANSI VeryInv	19,61	0,491	2
8	F	ANSI ExtInv	28,2	0,1217	2
9		ANSI LongInv	0,086	0,185	0,02
10		ANSI LongVeryInv	28,55	0,712	2
11		ANSI LongExtInv	64,07	0,250	2

Table 36 The constants of the standard dependent time characteristics

A parameter (Operation) serves for choosing overcurrent function of independent time delay or dependent one with type selection above.

Time multiplier of the inverse characteristics (TMS) is also a parameter to be preset.

The end of the effective range of the dependent time characteristics ( $G_D$ ) is:

$$G_D = 20 * G_s$$

Above this value the theoretical operating time is definite. The inverse type characteristics are also combined with a minimum time delay, the value of which is set by user parameter TOC46\_MinDel\_TPar\_ (Min. Time Delay).



The negative phase sequence components calculation is based on the Fourier components of the phase currents.

The binary output status signals of the negative sequence overcurrent protection function are the general starting and the general trip command of the function.

The negative sequence overcurrent protection function has a binary input signal, which serves the purpose of disabling the function. The conditions of disabling are defined by the user, applying the graphic equation editor.

### Technical data

Function	Value	Accuracy
Operating accuracy	$10 \leq G_s [\%] \leq 200$	< 2 %
Operate time accuracy		$\pm 5\%$ or $\pm 15$ ms, whichever is greater
Reset ratio	0,95	
Reset time * Dependent time charact. Definite time charact.	approx. 60 ms	<2 % or $\pm 35$ ms, whichever is greater
Transient overreach		< 2 %
Pickup time at $2 * G_s$	<40 ms	
Overshot time Dependent time charact. Definite time charact.	25 ms 45 ms	
Influence of time varying value of the input current (IEC 60255-151)		< 4 %

\* Measured with signal contacts

Table 37 Technical data of the negative sequence overcurrent protection function

### Parameters

#### Enumerated parameter

Parameter name	Title	Selection range	Default
Parameter for type selection			
TOC46_Oper_EPar_	Operation	Off, DefinitTime, IEC Inv, IEC VeryInv, IEC ExtInv, IEC LongInv, ANSI Inv, ANSI ModInv, ANSI VeryInv, ANSI ExtInv, ANSI LongInv, ANSI LongVeryInv, ANSI LongExtInv	Definit Time

Table 38 The enumerated parameter of the negative sequence overcurrent protection function

#### Integer parameter

Parameter name	Title	Unit	Min	Max	Step	Default
Starting current parameter:						
TOC46_StCurr_IPar_	Start Current	%	5	200	1	50

Table 39 The integer parameter of the negative sequence overcurrent protection function

**Float point parameter**

Parameter name	Title	Unit	Min	Max	Step	Default
Time multiplier of the inverse characteristics (OC module)						
TOC46_Multip_FPar_	Time Multiplier		0.05	999	0.01	1.0

\*Valid for inverse type characteristics

*Table 40 The float point parameter of the time overcurrent protection function*

**Timer parameters**

Parameter name	Title	Unit	Min	Max	Step	Default
Minimal time delay for the inverse characteristics:						
TOC46_MinDel_TPar_	Min Time Delay*	msec	0	60000	1	100
Definite time delay:						
TOC46_DefDel_TPar_	Definite Time Delay**	msec	0	60000	1	100
Reset time delay for the inverse characteristics:						
TOC46_Reset_TPar_	Reset Time*	msec	0	60000	1	100

\*Valid for inverse type characteristics

\*\*Valid for definite type characteristics only

*Table 41 The timer parameter of the negative sequence overcurrent protection function*

### 1.3.1.9 Line thermal protection function (TTR49L)

Basically, line thermal protection measures the three sampled phase currents. RMS values are calculated and the temperature calculation is based on the highest RMS value of the phase currents.

The temperature calculation is based on the step-by-step solution of the thermal differential equation. This method yields “overtemperature”, meaning the temperature above the ambient temperature. Accordingly, the temperature of the protected object is the sum of the calculated “overtemperature” and the ambient temperature.

If the calculated temperature (calculated “overtemperature”+ambient temperature) is above the threshold values, alarm, trip and restart blocking status signals are generated.

For correct setting, the following values must be measured and set as parameters: rated load current is the continuous current applied for the measurement, rated temperature is the steady state temperature at rated load current, base temperature is the temperature of the environment during the measurement and the time constant is the measured heating/cooling time constant of the exponential temperature function.

When energizing the protection device, the algorithm permits the definition of the starting temperature as the initial value of the calculated temperature. The parameter Startup Term. is the initial temperature above the temperature of the environment as compared to the rated temperature above the temperature of the environment

The ambient temperature can be measured using e.g. a temperature probe generating electric analog signals proportional to the temperature. In the absence of such measurement, the temperature of the environment can be set using the dedicated parameter TTR49L\_Amb\_IPar\_ (Ambient Temperature). The selection between parameter value and direct measurement is made by setting the binary Boolean parameter.

The problem of metal elements (the protected line) exposed to the sun is that they are overheated as compared to the „ambient” temperature even without a heating current; furthermore, they are cooled mostly by the wind and the heat transfer coefficient is highly dependent on the effects of the wind. As the overhead lines are located in different geographical environments along the tens of kilometers of the route, the effects of the sun and the wind cannot be considered in detail. The best approximation is to measure the temperature of a piece of overhead line without current but exposed to the same environmental conditions as the protected line itself.

The application of thermal protection of the overhead line is a better solution than a simple overcurrent-based overload protection because thermal protection “remembers” the preceding load states of the line and the setting of the thermal protection does not need so a high security margin between the permitted current and the permitted continuous thermal current of the line. In a broad range of load states and in a broad range of ambient temperatures this permits the better exploitation of the thermal and consequently current carrying capacity of the line.

The thermal differential equation to be solved is:

$$\frac{d\Theta}{dt} = \frac{1}{T} \left( \frac{I^2(t)R}{hA} - \Theta \right), \text{ and the definition of the heat time constant is: } T = \frac{cm}{hA}$$

In this differential equation:

I(t) (RMS)	heating current, the RMS value usually changes over time;
R	resistance of the line;
c	specific heat capacity of the conductor;
m	mass of the conductor;
θ	rise of the temperature above the temperature of the environment;
h	heat transfer coefficient of the surface of the conductor;
A	area of the surface of the conductor;
t	time.

The solution of the thermal differential equation for constant current is the temperature as the function of time (the mathematical derivation of this equation is described in a separate document):

$$\Theta(t) = \frac{I^2 R}{hA} \left( 1 - e^{-\frac{t}{T}} \right) + \Theta_o e^{-\frac{t}{T}}$$

where

$\Theta_o$  is the starting temperature.

Remember that the calculation of the measurable temperature is as follows:

$$\text{Temperature}(t) = \Theta(t) + \text{Temp\_ambient}$$

where

Temp\_ambient is the ambient temperature.

In a separate document it is proven that some more easily measurable parameters can be introduced instead of the aforementioned ones. Thus, the general form of equation above is:

$$H(t) = \frac{\Theta(t)}{\Theta_n} = \frac{I^2}{I_n^2} \left( 1 - e^{-\frac{t}{T}} \right) + \frac{\Theta_o}{\Theta_n} e^{-\frac{t}{T}}$$

where:

$H(t)$  is the „thermal level” of the heated object, this is the temperature as a percentage of the  $\Theta_n$  reference temperature. (This is a dimensionless quantity but it can also be expressed in a percentage form.)

$\Theta_n$  is the reference temperature above the temperature of the environment, which can be measured in steady state, in case of a continuous  $I_n$  reference current.

$I_n$  is the reference current (can be considered as the nominal current of the heated object). If it flows continuously, then the reference temperature can be measured in steady state.

$\frac{\Theta_o}{\Theta_n}$  is a parameter of the starting temperature related to the reference temperature

The *RMS calculations modul* calculate the RMS values of the phase currents individually. The sampling frequency of the calculations is 1 kHz; therefore, theoretically, the frequency components below 500Hz are considered correctly in the RMS values. This module is not part of the thermal overload function; it belongs to the preparatory phase.

The *Max selection module* selects the maximal value of the three RMS phase currents.

The *Thermal replica module* solves the first order thermal differential equation using a simple step-by-step method and compares the calculated temperature to the values set by parameters. The temperature sensor value proportional to the ambient temperature can be an input (this signal is optional, defined at parameter setting).

The function can be disabled by parameter, or generates a trip pulse if the calculated temperature exceeds the trip value, or generates a trip signal if the calculated temperature exceeds the trip value given by a parameter but it resets only if the temperature cools below the “Unlock temperature”.

The line thermal protection function has two binary input signals. The conditions of the input signal are defined by the user, applying the graphic equation editor. One of the signals can block the line thermal protection function, the other one can reset the accumulated heat and set the temperature to the defined value for the subsequent heating test procedure.

**Technical data**

Function	Accuracy
Operate time at $I > 1.2 \cdot I_{trip}$	$< 3\%$ or $< + 20$ ms

*Table 42 Technical data of the line thermal protection function*

**Parameters****Enumerated parameter**

Parameter name	Title	Selection range	Default
Parameter for mode of operation			
TTR49L_Oper_EPar_	Operation	Off, Pulsed, Locked	Pulsed

*Table 43 The enumerated parameter of the line thermal protection function*

The meaning of the enumerated values is as follows:

- Off the function is switched off; no output status signals are generated;
- Pulsed the function generates a trip pulse if the calculated temperature exceeds the trip value
- Locked the function generates a trip signal if the calculated temperature exceeds the trip value. It resets only if the temperature cools below the "Unlock temperature".

**Integer parameters**

Parameter name	Title	Unit	Min	Max	Step	Default
Alarm Temperature						
TTR49L_Alm_IPar_	Alarm Temperature	deg	60	200	1	80
Trip Temperature						
TTR49L_Trip_IPar_	Trip Temperature	deg	60	200	1	100
Rated Temperature						
TTR49L_Max_IPar_	Rated Temperature	deg	60	200	1	100
Base Temperature						
TTR49L_Ref_IPar_	Base Temperature	deg	0	40	1	25
Unlock Temperature						
TTR49L_Unl_IPar_	Unlock Temperature	deg	20	200	1	60
Ambient Temperature						
TTR49L_Amb_IPar_	Ambient Temperature	deg	0	40	1	25
Startup Term.						
TTR49L_Str_IPar_	Startup Term	%	0	60	1	0
Rated Load Current						
TTR49L_Inom_IPar_	Rated Load Current	%	20	150	1	100
Time constant						
TTR49L_pT_IPar_	Time Constant	min	1	999	1	10

*Table 44 The integer parameters of the line thermal protection function*

**Boolean parameter**

Boolean parameter	Signal title	Selection range	Default
Parameter for ambient temperature sensor application			
TTR49L_Sens_BPar_	Temperature Sensor	No, Yes	No

*Table 45 The boolean parameter of the line thermal protection function*

### 1.3.1.10 Definite time overvoltage protection function (TOV59)

The definite time overvoltage protection function measures three voltages. The measured values of the characteristic quantity are the RMS values of the basic Fourier components of the phase voltages.

The Fourier calculation inputs are the sampled values of the three phase voltages (UL1, UL2, UL3), and the outputs are the basic Fourier components of the analyzed voltages (UL1Four, UL2Four, UL3Four). They are not part of the TOV59 function; they belong to the preparatory phase.

The function generates start signals for the phases individually. The general start signal is generated if the voltage in any of the three measured voltages is above the level defined by parameter setting value.

The function generates a trip command only if the definite time delay has expired and the parameter selection requires a trip command as well.

The overvoltage protection function has a binary input signal, which serves the purpose of disabling the function. The conditions of disabling are defined by the user, applying the graphic equation editor.

#### Technical data

Function	Value	Accuracy
Pick-up starting accuracy		< ± 0,5 %
Blocking voltage		< ± 1,5 %
Reset time		
U< → Un	60 ms	
U< → 0	50 ms	
Operate time accuracy		< ± 20 ms
Minimum operate time	50 ms	

Table 46 Technical data of the definite time overvoltage protection function

#### Parameters

##### Enumerated parameter

Parameter name	Title	Selection range	Default
Enabling or disabling the overvoltage protection function			
TOV59_Oper_EPar_	Operation	Off, On	On

Table 47 The enumerated parameter of the definite time overvoltage protection function

##### Integer parameter

Parameter name	Title	Unit	Min	Max	Step	Default
Voltage level setting. If the measured voltage is above the setting value, the function generates a start signal.						
TOV59_StVol_IPar_	Start Voltage	%	30	130	1	63

Table 48 The integer parameter of the definite time overvoltage protection function

##### Boolean parameter

Parameter name	Title	Default
Enabling start signal only:		
TOV59_StOnly_BPar_	Start Signal Only	FALSE

Table 49 The boolean parameter of the definite time overvoltage protection function

##### Timer parameter

Parameter name	Title	Unit	Min	Max	Step	Default
Time delay of the overvoltage protection function.						
TOV59_Delay_TPar_	Time Delay	ms	0	60000	1	100

Table 50 The timer parameter of the definite time overvoltage protection function

### 1.3.1.11 Definite time undervoltage protection function (TUV27)

The definite time undervoltage protection function measures the RMS values of the fundamental Fourier component of three phase voltages.

The Fourier calculation inputs are the sampled values of the three phase voltages (UL1, UL2, UL3), and the outputs are the basic Fourier components of the analyzed voltages (UL1Four, UL2Four, UL3Four). They are not part of the TUV27 function; they belong to the preparatory phase.

The function generates start signals for the phases individually. The general start signal is generated if the voltage is below the preset starting level parameter setting value and above the defined blocking level.

The function generates a trip command only if the definite time delay has expired and the parameter selection requires a trip command as well.

The operation mode can be chosen by the type selection parameter. The function can be disabled, and can be set to "1 out of 3", "2 out of 3", and "All".

The overvoltage protection function has a binary input signal, which serves the purpose of disabling the function. The conditions of disabling are defined by the user, applying the graphic equation editor.

#### Technical data

Function	Value	Accuracy
Pick-up starting accuracy		< ± 0,5 %
Blocking voltage		< ± 1,5 %
Reset time U> → Un U> → 0	50 ms 40 ms	
Operate time accuracy		< ± 20 ms
Minimum operate time	50 ms	

Table 51 Technical data of the definite time undervoltage protection function

#### Parameters

##### Enumerated parameter

Parameter name	Title	Selection range	Default
Parameter for type selection			
TUV27_Oper_EPar_	Operation	Off, 1 out of 3, 2 out of 3, All	1 out of 3

Table 52 The enumerated parameter of the definite time undervoltage protection function

##### Integer parameters

Parameter name	Title	Unit	Min	Max	Step	Default
Starting voltage level setting						
TUV27_StVol_IPar_	Start Voltage	%	30	130	1	52
Blocking voltage level setting						
TUV27_BlkVol_IPar_	Block Voltage	%	0	20	1	10

Table 53 The integer parameters of the definite time undervoltage protection function

##### Boolean parameter

Parameter name	Title	Default
Enabling start signal only:		
TUV27_StOnly_BPar_	Start Signal Only	FALSE

Table 54 The boolean parameter of the definite time undervoltage protection function

##### Timer parameters

Parameter name	Title	Unit	Min	Max	Step	Default
Time delay of the undervoltage protection function.						
TUV27_Delay_TPar_	Time Delay	ms	0	60000	1	100

Table 55 The timer parameter of the definite time undervoltage protection function

### 1.3.1.12 Residual definite time overvoltage protection function (TOV59N)

The residual definite time overvoltage protection function operates according to definite time characteristics, using the RMS values of the fundamental Fourier component of the zero sequence voltage ( $U_N=3U_0$ ).

The Fourier calculation inputs are the sampled values of the residual or neutral voltage ( $U_N=3U_0$ ) and the outputs are the RMS value of the basic Fourier components of those.

The function generates start signal if the residual voltage is above the level defined by parameter setting value.

The function generates a trip command only if the definite time delay has expired and the parameter selection requires a trip command as well.

The residual overvoltage protection function has a binary input signal, which serves the purpose of disabling the function. The conditions of disabling are defined by the user, applying the graphic equation editor.

#### Technical data

Function	Value	Accuracy
Pick-up starting accuracy	2 – 8 % 8 – 60 %	< ± 2 % < ± 1.5 %
Reset time U> → Un U> → 0	60 ms 50 ms	
Operate time	50 ms	< ± 20 ms

Table 56 Technical data of the residual definite time overvoltage protection function

#### Parameters

##### Enumerated parameter

Parameter name	Title	Selection range	Default
Parameter for enabling/disabling:			
TOV59N_Oper_EPar_	Operation	Off, On	On

Table 57 The enumerated parameter of the residual definite time overvoltage protection function

##### Integer parameter

Parameter name	Title	Unit	Min	Max	Step	Default
Starting voltage parameter:						
TOV59N_StVol_IPar_	Start Voltage	%	2	60	1	30

Table 58 The integer parameter of the residual definite time overvoltage protection function

##### Boolean parameter

Parameter name	Title	Default
Enabling start signal only:		
TOV59N_StOnly_BPar_	Start Signal Only	FALSE

Table 59 The boolean parameter of the residual definite time overvoltage protection function

##### Timer parameter

Parameter name	Title	Unit	Min	Max	Step	Default
Definite time delay:						
TOV59N_Delay_TPar_	Time Delay	ms	0	60000	1	100

Table 60 The time parameter of the residual definite time overvoltage protection function



### 1.3.1.13 Over-frequency protection function (TOF81)

The deviation of the frequency from the rated system frequency indicates unbalance between the generated power and the load demand. If the available generation is large compared to the consumption by the load connected to the power system, then the system frequency is above the rated value. The over-frequency protection function is usually applied to decrease generation to control the system frequency.

Another possible application is the detection of unintended island operation of distributed generation and some consumers. In the island, there is low probability that the power generated is the same as consumption; accordingly, the detection of high frequency can be one of the indication of island operation.

Accurate frequency measurement is also the criterion for the synchro-check and synchro-switch functions.

The accurate frequency measurement is performed by measuring the time period between two rising edges at zero crossing of a voltage signal. For the acceptance of the measured frequency, at least four subsequent identical measurements are needed. Similarly, four invalid measurements are needed to reset the measured frequency to zero. The basic criterion is that the evaluated voltage should be above 30% of the rated voltage value.

The over-frequency protection function generates a start signal if at least five measured frequency values are above the preset level.

Time delay can also be set.

The function can be enabled/disabled by a parameter.

The over-frequency protection function has a binary input signal. The conditions of the input signal are defined by the user, applying the graphic equation editor. The signal can block the under-frequency protection function.

#### Technical data

Function	Range	Accuracy
Operate range	40 - 70 Hz	30 mHz
Effective range	45 - 55 Hz / 55 - 65 Hz	2 mHz
Operate time		min 140 ms
Time delay	140 – 60000 ms	± 20 ms
Reset ratio		0,99

Table 61 Technical data of the over-frequency protection function

#### Parameters

##### Enumerated parameter

Parameter name	Title	Selection range	Default
Selection of the operating mode			
TOF81_Oper_EPar_	Operation	Off,On	On

Table 62 The enumerated parameter of the over-frequency protection function

##### Boolean parameter

Parameter name	Title	Default
Enabling start signal only:		
TOF81_StOnly_BPar_	Start Signal Only	FALSE

Table 63 The boolean parameter of the over-frequency protection function

##### Float point parameter

Parameter name	Title	Unit	Min	Max	Step	Default
Setting value of the comparison						
TOF81_St_FPar_	Start Frequency	Hz	40	60	0.01	51

Table 64 The float point parameter of the over-frequency protection function

##### Timer parameter

Parameter name	Title	Unit	Min	Max	Step	Default
Time delay						
TOF81_Del_TPar_	Time Delay	msec	100	60000	1	200

Table 65 The timer parameter of the over-frequency protection function

### 1.3.1.14 Underfrequency protection function (TUF81)

The deviation of the frequency from the rated system frequency indicates unbalance between the generated power and the load demand. If the available generation is small compared to the consumption by the load connected to the power system, then the system frequency is below the rated value. The under-frequency protection function is usually applied to increase generation or for load shedding to control the system frequency.

Another possible application is the detection of unintended island operation of distributed generation and some consumers. In the island, there is low probability that the power generated is the same as consumption; accordingly, the detection of low frequency can be one of the indications of island operation.

Accurate frequency measurement is also the criterion for the synchro-check and synchro-switch functions.

The accurate frequency measurement is performed by measuring the time period between two rising edges at zero crossing of a voltage signal. For the acceptance of the measured frequency, at least four subsequent identical measurements are needed. Similarly, four invalid measurements are needed to reset the measured frequency to zero. The basic criterion is that the evaluated voltage should be above 30% of the rated voltage value.

The under-frequency protection function generates a start signal if at least five measured frequency values are below the setting value.

Time delay can also be set.

The function can be enabled/disabled by a parameter.

The under-frequency protection function has a binary input signal. The conditions of the input signal are defined by the user, applying the graphic equation editor. The signal can block the under-frequency protection function.

#### Technical data

Function	Range	Accuracy
Operate range	40 - 70 Hz	30 mHz
Effective range	45 - 55 Hz / 55 - 65 Hz	2 mHz
Operate time		min 140 ms
Time delay	140 – 60000 ms	± 20 ms
Reset ratio		0,99

Table 66 Technical data of the under-frequency protection function

#### Parameters

##### Enumerated parameter

Parameter name	Title	Selection range	Default
Selection of the operating mode			
TUF81_Oper_EPar_	Operation	Off, On	On

Table 67 The enumerated parameter of the under-frequency protection function

##### Boolean parameter

Parameter name	Title	Default
Enabling start signal only:		
TUF81_StOnly_BPar_	Start Signal Only	FALSE

Table 68 The boolean parameter of the under-frequency protection function

##### Float point parameter

Parameter name	Title	Unit	Min	Max	Digits	Default
Preset value of the comparison						
TUF81_St_FPar_	Start Frequency	Hz	40	60	0.01	49

Table 69 The float point parameter of the under-frequency protection function

##### Timer parameter

Parameter name	Title	Unit	Min	Max	Step	Default
Time delay						
TUF81_Del_TPar_	Time Delay	ms	100	60000	1	200

Table 70 The timer parameter of the under-frequency protection function

### 1.3.1.15 Rate of change of frequency protection function (FRC81)

The deviation of the frequency from the rated system frequency indicates unbalance between the generated power and the load demand. If the available generation is large compared to the consumption by the load connected to the power system, then the system frequency is above the rated value, and if it is small, the frequency is below the rated value. If the unbalance is large, then the frequency changes rapidly. The rate of change of frequency protection function is usually applied to reset the balance between generation and consumption to control the system frequency.

Another possible application is the detection of unintended island operation of distributed generation and some consumers. In the island, there is low probability that the power generated is the same as consumption; accordingly, the detection of a high rate of change of frequency can be an indication of island operation.

Accurate frequency measurement is also the criterion for the synchro-switch function.

The source for the rate of change of frequency calculation is an accurate frequency measurement.

In some applications, the frequency is measured based on the weighted sum of the phase voltages.

The accurate frequency measurement is performed by measuring the time period between two rising edges at zero crossing of a voltage signal. For the acceptance of the measured frequency, at least four subsequent identical measurements are needed. Similarly, four invalid measurements are needed to reset the measured frequency to zero. The basic criterion is that the evaluated voltage should be above 30% of the rated voltage value.

The rate of change of frequency protection function generates a start signal if the  $df/dt$  value is above the setting value. The rate of change of frequency is calculated as the difference of the frequency at the present sampling and at three periods earlier.

Time delay can also be set.

The function can be enabled/disabled by a parameter.

The rate of change of frequency protection function has a binary input signal. The conditions of the input signal are defined by the user, applying the graphic equation editor. The signal can block the rate of change of frequency protection function.

#### Technical data

Function	Effective range	Accuracy
Operating range	-5 - -0.05 and +0.05 - +5 Hz/sec	
Pick-up accuracy		±20 mHz/sec
Operate time	min 140 ms	
Time delay	140 – 60000 ms	± 20 ms

Table 71 Technical data of the rate of change of frequency protection function

#### Parameters

##### Enumerated parameter

Parameter name	Title	Selection range	Default
Selection of the operating mode			
FRC81_Oper_EPar	Operation	Off,On	On

Table 72 The enumerated parameter of the rate of change of frequency protection function

##### Boolean parameter

Parameter name	Title	Default
Enabling start signal only:		
FRC81_StOnly_BPar	Start Signal Only	True

Table 73 The boolean parameter of the rate of change of frequency protection function

**Float point parameter**

Parameter name	Title	Unit	Min	Max	Step	Default
Setting value of the comparison						
FRC81_St_FPar_	Start df/dt	Hz/sec	-5	5	0.01	0.5

*Table 74 The float point parameter of the rate of change of frequency protection function*

**Timer parameters**

Parameter name	Title	Unit	Min	Max	Step	Default
Time delay						
FRC81_Del_TPar_	Time Delay	msec	100	60000	1	200

*Table 75 The timer parameter of the rate of change of frequency protection function*

---

### 1.3.1.16 Synchro check, synchro switch function (SYN25)

Several problems can occur in the electric power system if the circuit breaker closes and connects two systems operating asynchronously. The high current surge can cause damage in the interconnecting elements, the accelerating forces can overstress the shafts of rotating machines or, at last, the actions taken by the protective system can result in the unwanted separation of parts of the electric power system.

To prevent such problems, this function checks whether the systems to be interconnected are operating synchronously. If yes, then the close command is transmitted to the circuit breaker. In case of asynchronous operation, the close command is delayed to wait for the appropriate vector position of the voltage vectors on both sides of the circuit breaker. If the conditions for safe closing cannot be fulfilled within an expected time, then closing is declined.

The conditions for safe closing are as follows:

- The difference of the voltage magnitudes is below the declared limit,
- The difference of the frequencies is below the declared limit and
- The angle difference between the voltages on both sides of the circuit breaker is within the declared limit.

The function processes both automatic reclosing and manual close commands.

The limits for automatic reclosing and manual close commands can be set independently of each other.

The function compares the voltage of the line and the voltage of one of the bar sections (Bus1 or Bus2). The bus selection is made automatically based on a binary input signal defined by the user applying the graphic equation editor.

As to voltages: any phase-to-ground or phase-to-phase voltage can be selected.

The function processes the signals of the voltage transformer supervision function and enables the close command only in case of plausible voltages.

There are three modes of operation:

- Energizing check:
  - Dead bus, live line,
  - Live bus, dead line,
  - Any Energizing Case (including Dead bus, dead line).
- Synchro check (Live line, live bus)
- Synchro switch (Live line, live bus)

If the conditions for “Energizing check” or “Synchro check” are fulfilled, then the function generates the release command, and in case of a manual or automatic close request, the close command is generated.

If the conditions for energizing or synchronous operation are not met when the close request is received, then synchronous switching is attempted within the set time-out. In this case, the rotating vectors must fulfill the conditions for safe switching within the declared waiting time: at the moment the contacts of the circuit breaker are closed, the voltage vectors must match each other with appropriate accuracy. For this mode of operation, the expected operating time of the circuit breaker must be set as a parameter value, to generate the close command in advance taking the relative vector rotation speed into consideration.

The started checking procedure can be interrupted by a cancel command defined by the user in the graphic equation editor.

In “bypass” operation mode, the function generates the release signals and simply transmits the close command.

The function can be started by the switching request signals initiated both the automatic reclosing and the manual closing. The binary input signals are defined by the user, applying the graphic equation editor.

Blocking signal of the function are defined by the user, applying the graphic equation editor.

Blocking signal of the voltage transformer supervision function for all voltage sources are defined by the user, applying the graphic equation editor.

Signal to interrupt (cancel) the automatic or the manual switching procedure are defined by the user, applying the graphic equation editor.

### Technical data

Function	Effective range	Accuracy in the effective range
Rated Voltage $U_n$	100/200V, parameter setting	
Voltage effective range	10-110 % of $U_n$	$\pm 1\%$ of $U_n$
Frequency	47.5 – 52.5 Hz	$\pm 10$ mHz
Phase angle		$\pm 3^\circ$
Operate time	Setting value	$\pm 3$ ms
Reset time	<50 ms	
Reset ratio	0.95 $U_n$	

Table 76 Technical data of the rate of synchro check protection function

### Parameters

#### Enumerated parameters

Parameter name	Title	Selection range	Default
Selection of the processed voltage			
SYN25_VoltSel_EPar_	Voltage Select	L1-N,L2-N,L3-N,L1-L2,L2-L3,L3-L1	L1-N
Operation mode for automatic switching			
SYN25_OperA_EPar_	Operation Auto	Off, On, ByPass	On
Enabling/disabling automatic synchro switching			
SYN25_SwOperA_EPar_	SynSW Auto	Off, On	On
Energizing mode for automatic switching			
SYN25_EnOperA_EPar_	Energizing Auto	Off, DeadBus LiveLine, LiveBus DeadLine, Any energ case	DeadBus LiveLine
Operation mode for manual switching			
SYN25_OperM_EPar_	Operation Man	Off, On, ByPass	On
Enabling/disabling manual synchro switching			
SYN25_SwOperM_EPar_	SynSW Man	Off, On	On
Energizing mode for manual switching			
SYN25_EnOperM_EPar_	Energizing Man	Off,DeadBus LiveLine, LiveBus DeadLine, Any energ case	DeadBus LiveLine

Table 77 The enumerated parameters of the rate of synchro check protection function

**Integer parameters**

Parameter name	Title	Unit	Min	Max	Step	Default
Voltage limit for "live line" detection						
SYN25_LiveU_IPar_	U Live	%	60	110	1	70
Voltage limit for "dead line" detection						
SYN25_DeadU_IPar_	U Dead	%	10	60	1	30
Voltage difference for automatic synchro checking mode						
SYN25_ChkUdA_IPar_	Udiff SynCheck Auto	%	5	30	1	10
Voltage difference for automatic synchro switching mode						
SYN25_SwUdA_IPar_	Udiff SynSW Auto	%	5	30	1	10
Phase difference for automatic switching						
SYN25_MaxPhDiffA_IPar_	MaxPhaseDiff Auto	deg	5	80	1	20
Voltage difference for manual synchro checking mode						
SYN25_ChkUdM_IPar_	Udiff SynCheck Man	%	5	30	1	10
Voltage difference for manual synchro switching mode						
SYN25_SwUdM_IPar_	Udiff SynSW Man	%	5	30	1	10
Phase difference for manual switching						
SYN25_MaxPhDiffM_IPar_	MaxPhaseDiff Man	deg	5	80	1	20

*Table 78 The integer parameters of the rate of synchro check protection function*

**Floating point parameters**

Parameter name	Title	Dim.	Min	Max	Default
Frequency difference for automatic synchro checking mode					
SYN25_ChkFrDA_FPar_	FrDiff SynCheck Auto	Hz	0.02	0.5	0.02
Frequency difference for automatic synchro switching mode					
SYN25_SwFrDA_FPar_	FrDiff SynSW Auto	Hz	0.10	1.00	0.2
Frequency difference for manual synchro checking mode					
SYN25_ChkFrDM_FPar_	FrDiff SynCheck Man	Hz	0.02	0.5	0.02
Frequency difference for manual synchro switching mode					
SYN25_SwFrDM_FPar_	FrDiff SynSW Man	Hz	0.10	1.00	0.2

*Table 79 The float point parameters of the rate of synchro check protection function*

**Timer parameters**

Parameter name	Title	Unit	Min	Max	Step	Default
Breaker operating time at closing						
SYN25_CBTrav_TPar_	Breaker Time	msec	0	500	1	80
Impulse duration for close command						
SYN25_SwPu_TPar_	Close Pulse	msec	10	60000	1	1000
Maximum allowed switching time						
SYN25_MaxSw_TPar_	Max Switch Time	msec	100	60000	1	2000

*Table 80 The timer parameters of the rate of synchro check protection function*

### 1.3.1.17 Auto-reclose protection (REC79MV)

The MV automatic reclosing function can realize up to four shots of reclosing for medium-voltage networks. The dead time can be set individually for each reclosing and separately for earth faults and for multi-phase faults. All shots are of three phase reclosing.

The starting signal of the cycles can be generated by any combination of the protection functions or external signals of the binary inputs.

The automatic reclosing function is triggered if as a consequence of a fault a protection function generates a trip command to the circuit breaker and the protection function resets because the fault current drops to zero or the circuit breaker's auxiliary contact signals open state. According to the preset parameter values, either of these two conditions starts counting the dead time, at the end of which the MV automatic reclosing function generates a close command automatically. If the fault still exists or reappears, then within the "Reclaim time" the protection functions picks up again and the subsequent cycle is started. If the fault still exists at the end of the last cycle, the MV automatic reclosing function trips and generates the signal for final trip. If no pickup is detected within this time, then the MV automatic reclosing cycle resets and a new fault will start the procedure with the first cycle again.

At the moment of generating the close command, the circuit breaker must be ready for operation, which is signaled via the binary input "CB Ready". The preset parameter value "CB Supervision time" decides how long the MV automatic reclosing function is allowed to wait at the end of the dead time for this signal. If the signal is not received during this dead time extension, then the MV automatic reclosing function terminates.

Depending on binary parameter settings, the automatic reclosing function block can accelerate trip commands of the individual reclosing cycles. This function needs user-programmed graphic equations to generate the accelerated trip command.

The duration of the close command depends on preset parameter value "Close command time", but the close command terminates if any of the protection functions issues a trip command.

The MV automatic reclosing function can control up to four reclosing cycles. Depending on the preset parameter values "EarthFaults Rec,Cycle" and "PhaseFaults Rec,Cycle", there are different modes of operation, both for earth faults and for multi-phase faults:

Disabled	No automatic reclosing is selected,
1. Enabled	Only one automatic reclosing cycle is selected,
1.2. Enabled	Two automatic reclosing cycles are activated,
1.2.3. Enabled	Three automatic reclosing cycles are activated,
1.2.3.4. Enabled	All automatic reclosing cycles are activated.

The function can be switched Off /On using the parameter "Operation".

The user can also block the MV automatic reclosing function applying the graphic equation editor. The binary status variable to be programmed is "Block".

Depending on the preset parameter value "Reclosing started by", the MV automatic reclosing function can be started either by resetting of the TRIP command or by the binary signal indicating the open state of the circuit breaker.

If the reset state of the TRIP command is selected to start the MV automatic reclosing function, then the conditions are defined by the user applying the graphic equation editor. The binary status variable to be programmed is "AutoReclosing Start".

If the open state of the circuit breaker is selected to start the MV automatic reclosing function, then additionally to programming the "AutoReclosing Start" signal, the conditions for detecting the open state of the CB are defined by the user applying the graphic equation editor.



For all four reclosing cycles, separate dead times can be defined for line-to-line faults and for earth faults. The dead time counter of any reclosing cycle is started by the starting signal but starting can be delayed.

Reclosing is possible only if the conditions required by the “synchro-check” function are fulfilled. The conditions are defined by the user applying the graphic equation editor. The HV automatic reclosing function waits for a pre-programmed time for this signal. This time is defined by the user. If the “SYNC Release” signal is not received during the running time of this timer, then the “synchronous switch” operation is started. If no synchronous switching is possible, then the MV automatic reclosing function resets.

In case of a manual close command which is assigned to the binary input “Manual Close” using graphic equation programming, a preset parameter value decides how long the MV automatic reclosing function should be disabled after the manual close command.

The MV automatic reclosing function can be blocked by a binary input. The conditions are defined by the user applying the graphic equation editor.

### Technical data

Function	Accuracy
Operating time	±1% of setting value or ±30 ms

*Table 81 Technical data of the auto-reclosing protection function*

### Parameters

#### Enumerated parameters

Parameter name	Title	Selection range	Default
Switching ON/OFF the MV automatic reclosing function			
REC79_Op_EPar_	Operation	Off, On	On
Selection of the number of reclosing sequences in case of earth faults			
REC79_EFCycEn_EPar_	EarthFault RecCycle	Disabled, 1. Enabled, 1.2. Enabled, 1.2.3. Enabled, 1.2.3.4. Enabled	1. Enabled
Selection of the number of reclosing sequences in case of line-to-line faults			
REC79_PhFCycEn_EPar_	PhaseFault RecCycle	Disabled, 1. Enabled, 1.2. Enabled, 1.2.3. Enabled, 1.2.3.4. Enabled	1. Enabled
Selection of triggering the dead time counter (trip signal reset or circuit breaker open position)			
REC79_St_EPar_	Reclosing Started by	Trip reset, CB open	Trip reset

*Table 82 The enumerated parameters of the auto-reclosing protection function*

**Timer parameters**

Parameter name	Title	Unit	Min	Max	Step	Default
Dead time setting for the first reclosing cycle for line-to-line fault						
REC79_PhDT1_TPar_	1. Dead Time Ph	msec	0	100000	10	500
Dead time setting for the second reclosing cycle for line-to-line fault						
REC79_PhDT2_TPar_	2. Dead Time Ph	msec	10	100000	10	600
Dead time setting for the third reclosing cycle for line-to-line fault						
REC79_PhDT3_TPar_	3. Dead Time Ph	msec	10	100000	10	700
Dead time setting for the fourth reclosing cycle for line-to-line fault						
REC79_PhDT4_TPar_	4. Dead Time Ph	msec	10	100000	10	800
Dead time setting for the first reclosing cycle for earth fault						
REC79_EFDT1_TPar_	1. Dead Time EF	msec	0	100000	10	1000
Dead time setting for the second reclosing cycle for earth fault						
REC79_EF DT2_TPar_	2. Dead Time EF	msec	10	100000	10	2000
Dead time setting for the third reclosing cycle for earth fault						
REC79_EF DT3_TPar_	3. Dead Time EF	msec	10	100000	10	3000
Dead time setting for the fourth reclosing cycle for earth fault						
REC79_EF DT4_TPar_	4. Dead Time EF	msec	10	100000	10	4000
Reclaim time setting						
REC79_Rec_TPar_	Reclaim Time	msec	100	100000	10	2000
Impulse duration setting for the CLOSE command						
REC79_Close_TPar_	Close Command Time	msec	10	10000	10	100
Setting of the dynamic blocking time						
REC79_DynBlk_TPar_	Dynamic Blocking Time	msec	10	100000	10	1500
Setting of the blocking time after manual close command						
REC79_MC_TPar_	Block after Man Close	msec	0	100000	10	1000
Setting of the action time (max. allowable duration between protection start and trip)						
REC79_Act_TPar_	Action Time	msec	0	20000	10	1000
Limitation of the starting signal (trip command is too long or the CB open signal received too late)						
REC79_MaxSt_TPar_	Start Signal Max Time	msec	0	10000	10	1000
Max. delaying the start of the dead-time counter						
REC79_DtDel_TPar_	DeadTime Max Delay	msec	0	100000	10	3000
Waiting time for circuit breaker ready to close signal						
REC79_CBTO_TPar_	CB Supervision Time	msec	10	100000	10	1000
Waiting time for synchronous state signal						
REC79_SYN1_TPar_	SynCheck Max Time	msec	500	100000	10	10000
Waiting time for synchronous switching signal						
REC79_SYN2_TPar_	SynSW Max Time	msec	500	100000	10	10000

*Table 83 The timer parameters of the auto-reclosing protection function*

**Boolean parameters**

Parameter name	Title	Default	Explanation
REC79_CBState_BPar_	CB State Monitoring	0	Enable CB state monitoring for "Not Ready" state
REC79_Acc1_BPar_	Accelerate 1.Trip	0	Accelerate trip command at starting cycle 1
REC79_Acc2_BPar_	Accelerate 2.Trip	0	Accelerate trip command at starting cycle 2
REC79_Acc3_BPar_	Accelerate 3.Trip	0	Accelerate trip command at starting cycle 3
REC79_Acc4_BPar_	Accelerate 4.Trip	0	Accelerate trip command at starting cycle 4
REC79_Acc5_BPar_	Accelerate FinTrip	0	Accelerate final trip command

*Table 84 The boolean parameters of the auto-reclosing protection function*

### 1.3.1.18 Current unbalance function (VCB60)

The current unbalance protection function (VCB60) can be applied to detect unexpected asymmetry in current measurement.

The applied method selects maximum and minimum phase currents (RMS value of the fundamental Fourier components). If the difference between them is above the setting limit, the function generates a start signal. It is a necessary precondition of start signal generation that the maximum of the currents be above 10 % of the rated current and below 150% of the rated current.

*The Fourier calculation modules* calculate the RMS value of the basic Fourier current components of the phase currents individually. They are not part of the VCB60 function; they belong to the preparatory phase.

*The analog signal processing module* processes the RMS value of the basic Fourier current components of the phase currents to prepare the signals for the decision. It calculates the maximum and the minimum value of the RMS values and the difference between the maximum and minimum of the RMS values of the fundamental Fourier components of the phase currents as a percentage of the maximum of these values ( $\Delta I$ ). If the maximum of the currents is above 10 % of the rated current and below 150% of the rated current and the  $\Delta I$  value is above the limit defined by the preset parameter (Start Current Diff) an output is generated to the decision module.

*The decision logic module* combines the status signals to generate the starting signal and the trip command of the function.

The trip command is generated after the defined time delay if trip command is enabled by the Boolean parameter setting.

The function can be disabled by parameter setting, and by an input signal programmed by the user with the graphic programming tool.

#### Technical data

Function	Value	Accuracy
Pick-up starting accuracy at In		< 2 %
Reset ratio	0.95	
Operate time	70 ms	

Table 85 Technical data of the current unbalance function

#### Parameters

##### Enumerated parameter

Parameter name	Title	Selection range	Default
Selection of the operating mode			
VCB60_Oper_EPar_	Operation	Off, On	On

Table 86 The enumerated parameter of the current unbalance function

##### Boolean parameter

Parameter name	Title	Explanation	Default
Selection for trip command			
VCB60_StOnly_BPar_	Start Signal Only	0 to generate trip command	0

Table 87 The boolean parameter of the current unbalance function

**Integer parameter**

---

Parameter name	Title	Unit	Min	Max	Step	Default
Phase difference current setting						
VCB60_StCurr_IPar_	Start Current Diff	%	10	90	1	50

*Table 88 The integer parameter of the current unbalance function***Timer parameter**

Parameter name	Title	Unit	Min	Max	Step	Default
Time delay						
VCB60_Del_TPar_	Time Delay	msec	100	60000	100	1000

*Table 89 The timer parameter of the current unbalance function*

### 1.3.1.19 Breaker failure protection function (BRF50)

After a protection function generates a trip command, it is expected that the circuit breaker opens and the fault current drops below the pre-defined normal level.

If not, then an additional trip command must be generated for all backup circuit breakers to clear the fault. At the same time, if required, a repeated trip command can be generated to the circuit breakers which are a priori expected to open.

The breaker failure protection function can be applied to perform this task.

The starting signal of the breaker failure protection function is usually the trip command of any other protection function assigned to the protected object. The user has the task to define these starting signals using the graphic equation editor, or if the operation of the individual phases is needed, then the start signals for the phases individually.

Two dedicated timers start at the rising edge of the start signals at the same time, one for the backup trip command and one for the repeated trip command, separately for operation in the individual phases. During the running time of the timers the function optionally monitors the currents, the closed state of the circuit breakers or both, according to the user's choice. The selection is made using an enumerated parameter.

If current supervision is selected by the user then the current limit values must be set correctly. The binary inputs indicating the status of the circuit breaker poles have no meaning.

If contact supervision is selected by the user then the current limit values have no meaning. The binary inputs indicating the status of the circuit breaker poles must be programmed correctly using the graphic equation editor.

If the parameter selection is "Current/Contact", the current parameters and the status signals must be set correctly. The breaker failure protection function resets only if all conditions for faultless state are fulfilled.

If at the end of the running time of the backup timer the currents do not drop below the pre-defined level, and/or the monitored circuit breaker is still in closed position, then a backup trip command is generated.

If repeated trip command is to be generated for the circuit breakers that are expected to open, then the enumerated parameter Retrip must be set to "On". In this case, at the end of the retrip timer(s) a repeated trip command is also generated in the phase(s) where the retrip timer(s) run off.

The pulse duration of the trip command is not shorter than the time defined by setting the parameter Pulse length.

The breaker failure protection function can be disabled by setting the enabling parameter to "Off".

Dynamic blocking (inhibition) is possible using the binary input Block. The conditions are to be programmed by the user, using the graphic equation editor.

#### Technical data

Function	Effective range	Accuracy
Current accuracy		<2 %
Retrip time	approx. 15 ms	
BF time accuracy		± 5 ms
Current reset time	20 ms	

*Table 90 Technical data of the breaker failure protection function*

**Parameters****Enumerated parameters**

Parameter name	Title	Selection range	Default
Selection of the operating mode			
BRF50_Oper_EPar_	Operation	Off, Current, Contact, Current/Contact	Current
Switching on or off of the repeated trip command			
BRF50_ReTr_EPar_	Retrip	Off, On	On

*Table 91 The enumerated parameters of the breaker failure protection function*

**Integer parameters**

Parameter name	Title	Unit	Min	Max	Step	Default
Phase current setting						
BRF50_StCurrPh_IPar_	Start Ph Current	%	20	200	1	30
Neutral current setting						
BRF50_StCurrN_IPar_	Start Res Current	%	10	200	1	20

*Table 92 The integer parameters of the breaker failure protection function*

**Timer parameters**

Parameter name	Title	Unit	Min	Max	Step	Default
Time delay for repeated trip command generation						
BRF50_TrDel_TPar_	Retrip Time Delay	msec	0	10000	1	200
Time delay for trip command generation for the backup circuit breaker(s)						
BRF50_BUDel_TPar_	Backup Time Delay	msec	60	10000	1	300
Trip command impulse duration						
BRF50_Pulse_TPar_	Pulse Duration	msec	0	60000	1	100

*Table 93 The timer parameters of the breaker failure protection function*

### 1.3.1.20 Directional over-power protection function (DOP32)

The directional over-power protection function can be applied to protect any elements of the electric power system mainly generators if the active and/or reactive power has to be limited.

#### Technical data

Function	Effective range	Accuracy
P,Q measurement	$I > 5\% I_n$	$< 3\%$

Table 94 Technical data of the directional over-power protection function

#### Parameters

##### Enumerated parameter

Parameter name	Title	Selection range	Default
Switching on/off of the function			
DOP32_Oper_EPar_	Operation	Off,On	On

Table 95 The enumerated parameter of the directional over-power protection function

##### Boolean parameter

Parameter name	Title	Default
Selection: start signal only or both start signal and trip command		
DOP32_StOnly_BPar_	Start Signal Only	0

Table 96 The Boolean parameter of the directional over-power protection function

##### Integer parameter

Parameter name	Title	Unit	Min	Max	Step	Default
Direction angle						
DOP32_RCA_IPar_	Direction Angle	deg	-179	180	1	0

Table 97 Integer parameter of the directional over-power protection function

##### Float parameter

Parameter name	Title	Unit	Min	Max	Step	Default
Minimum power setting						
DOP32_StPow_FPar_	Start Power	%	1	200	0.1	10

Table 98 Float parameter of the directional over-power protection function

##### Timer parameters

Parameter name	Title	Unit	Min	Max	Step	Default
Definite time delay of the trip command						
DOP32_Delay_TPar_	Time Delay	msec	0	60000	1	100

Table 99 Timer parameter of the directional over-power protection function

### 1.3.1.21 Directional under-power protection function (DUP32)

The directional under-power protection function can be applied mainly to protect any elements of the electric power system, mainly generators, if the active and/or reactive power has to be limited in respect of the allowed minimum power.

#### Technical data

Function	Effective range	Accuracy
P,Q measurement	$I > 5\% I_n$	$< 3\%$

Table 100 Technical data of the directional under-power protection function

#### Parameters

##### Enumerated parameter

Parameter name	Title	Selection range	Default
Switching on/off of the function			
DUP32_Oper_EPar_	Operation	Off, On	On

Table 101 The enumerated parameter of the directional under-power protection function

##### Boolean parameter

Parameter name	Title	Default
Selection: start signal only or both start signal and trip command		
DUP32_StOnly_BPar_	Start Signal Only	0

Table 102 The Boolean parameter of the directional under-power protection function

##### Integer parameter

Parameter name	Title	Unit	Min	Max	Step	Default
Direction angle						
DUP32_RCA_IPar_	Direction Angle	deg	-179	180	1	0

Table 103 Integer parameter of the directional under-power protection function

##### Float parameter

Parameter name	Title	Unit	Min	Max	Step	Default
Minimum power setting						
DUP32_StPow_FPar_	Start Power	%	1	200	0,1	10

Table 104 Float parameter of the directional under-power protection function

##### Timer parameter

Parameter name	Title	Unit	Min	Max	Step	Default
Definite time delay of the trip command						
DUP32_Delay_TPar_	Time Delay	msec	0	60000	1	100

Table 105 Timer parameter of the directional under-power protection function



### 1.3.1.22 Trip logic (TRC94)

The simple trip logic function operates according to the functionality required by the IEC 61850 standard for the “Trip logic logical node”. This simplified software module can be applied if only three-phase trip commands are required, that is, phase selectivity is not applied.

The function receives the trip requirements of the protective functions implemented in the device and combines the binary signals and parameters to the outputs of the device.

The trip requirements are programmed by the user, using the graphic equation editor. The aim of the decision logic is

- to define a minimal impulse duration even if the protection functions detect a very short-time fault.
- 

#### Technical data

Function		Accuracy
Impulse time duration	Setting value	<3 ms

Table 106 Technical data of the simple trip logic function

#### Parameters

##### Enumerated parameter

Parameter name	Title	Selection range	Default
Selection of the operating mode			
TRC94_Oper_EPar_	Operation	Off, On	On

Tables 107 The enumerated parameter of the decision logic

##### Timer parameter

Parameter name	Title	Unit	Min	Max	Step	Default
Minimum duration of the generated impulse						
TRC94_TrPu_TPar_	Min Pulse Duration	msec	50	60000	1	150

Table 108 Timer parameter of the decision logic

### 1.3.1.23 Dead line detection function (DLD)

The “Dead Line Detection” (DLD) function generates a signal indicating the dead or live state of the line. Additional signals are generated to indicate if the phase voltages and phase currents are above the pre-defined limits.

The task of the “Dead Line Detection” (DLD) function is to decide the Dead line/Live line state.

Criteria of “Dead line” state: all three phase voltages are below the voltage setting value AND all three currents are below the current setting value.

Criteria of “Live line” state: all three phase voltages are above the voltage setting value.

The details are described in the document *Dead line detection protection function block description*.

#### Technical data

Function	Value	Accuracy
Pick-up voltage		1%
Operation time	<20ms	
Reset ratio	0.95	

Table 109 Technical data of the dead line detection function

#### Parameters

##### Integer parameters

Parameter name	Title	Unit	Min	Max	Step	Default
Integer parameters of the dead line detection function						
DLD_ULev_IPar_	Min. Operate Voltage	%	10	100	1	60
DLD_ILev_IPar_	Min. Operate Current	%	2	100	1	10

Table 110 The integer parameters of the dead line detection function

### 1.3.1.24 Current input function (CT4)

If the factory configuration includes a current transformer hardware module, the current input function block is automatically configured among the software function blocks. Separate current input function blocks are assigned to each current transformer hardware module.

A current transformer hardware module is equipped with four special intermediate current transformers. (See Chapter 5 of the EuroProt+ hardware description document.) As usual, the first three current inputs receive the three phase currents (IL1, IL2, IL3), the fourth input is reserved for zero sequence current, for the zero sequence current of the parallel line or for any additional current. Accordingly, the first three inputs have common parameters while the fourth current input needs individual setting.

The role of the current input function block is to

- set the required parameters associated to the current inputs,
- deliver the sampled current values for disturbance recording,
- perform the basic calculations
  - Fourier basic harmonic magnitude and angle,
  - True RMS value;
- provide the pre-calculated current values to the subsequent software modules,
- deliver the basic calculated values for on-line displaying.

#### Operation of the current input algorithm

The current input function block receives the sampled current values from the internal operating system. The scaling (even hardware scaling) depends on parameter setting. See parameters CT4\_Ch13Nom\_EPar\_ (Rated Secondary I1-3) and CT4\_Ch4Nom\_EPar\_ (Rated Secondary I4). The options to choose from are 1A or 5A (in special applications, 0.2A or 1A). This parameter influences the internal number format and, naturally, accuracy. (A small current is processed with finer resolution if 1A is selected.)

If needed, the phase currents can be inverted by setting the parameter CT4\_Ch13Dir\_EPar\_ (Starpoint I1-3). This selection applies to each of the channels IL1, IL2 and IL3. The fourth current channel can be inverted by setting the parameter CT4\_Ch4Dir\_EPar\_ (Direction I4). This inversion may be needed in protection functions such as distance protection, differential protection or for any functions with directional decision.

These sampled values are available for further processing and for disturbance recording.

The performed basic calculation results the Fourier basic harmonic magnitude and angle and the true RMS value. These results are processed by subsequent protection function blocks and they are available for on-line displaying as well.

The function block also provides parameters for setting the primary rated currents of the main current transformer. This function block does not need that parameter setting. These values are passed on to function blocks such as displaying primary measured values, primary power calculation, etc.

#### Technical data

Function	Range	Accuracy
Current accuracy	20 – 2000% of In	±1% of In

Table 111 Technical data of the current input

## Parameters

### Enumerated parameters

Parameter name	Title	Selection range	Default
Rated secondary current of the first three input channels. 1A or 5A is selected by parameter setting, no hardware modification is needed.			
CT4_Ch13Nom_EPar_	Rated Secondary I1-3	1A,5A	1A
Rated secondary current of the fourth input channel. 1A or 5A is selected by parameter setting, no hardware modification is needed.			
CT4_Ch4Nom_EPar_	Rated Secondary I4	1A,5A (0.2A or 1A)	1A
Definition of the positive direction of the first three currents, given by location of the secondary star connection point			
CT4_Ch13Dir_EPar_	Starpoint I1-3	Line,Bus	Line
Definition of the positive direction of the fourth current, given as normal or inverted			
CT4_Ch4Dir_EPar_	Direction I4	Normal,Inverted	Normal

Table 112 The enumerated parameters of the current input function

### Floating point parameters

Parameter name	Title	Dim.	Min	Max	Default
Rated primary current of channel1					
CT4_Pri1_FPar_	Rated Primary I1	A	100	4000	1000
Rated primary current of channel2					
CT4_Pri2_FPar_	Rated Primary I2	A	100	4000	1000
Rated primary current of channel3					
CT4_Pri3_FPar_	Rated Primary I3	A	100	4000	1000
Rated primary current of channel4					
CT4_Pri4_FPar_	Rated Primary I4	A	100	4000	1000

Table 113 The floating point parameters of the current input function

NOTE: The rated primary current of the channels is not needed for the current input function block itself. These values are passed on to the subsequent function blocks.

The **measured values** of the current input function block.

Measured value	Dim.	Explanation
Current Ch - I1	A(secondary)	Fourier basic component of the current in channel IL1
Angle Ch - I1	degree	Vector position of the current in channel IL1
Current Ch - I2	A(secondary)	Fourier basic component of the current in channel IL2
Angle Ch - I2	degree	Vector position of the current in channel IL2
Current Ch - I3	A(secondary)	Fourier basic component of the current in channel IL3
Angle Ch - I3	degree	Vector position of the current in channel IL3
Current Ch - I4	A(secondary)	Fourier basic component of the current in channel I4
Angle Ch - I4	degree	Vector position of the current in channel I4

Table 114 The measured analogue values of the current input function

NOTE1: The scaling of the Fourier basic component is such that if pure sinusoid 1A RMS of the rated frequency is injected, the displayed value is 1A. (The displayed value does not depend on the parameter setting values "Rated Secondary".)

NOTE2: The reference of the vector position depends on the device configuration. If a voltage input module is included, then the reference vector (vector with angle 0 degree) is the vector calculated for the first voltage input channel of the first applied voltage input module. If no voltage input module is configured, then the reference vector (vector with angle 0 degree)

is the vector calculated for the first current input channel of the first applied current input module.

*Figure 6* shows an example of how the calculated Fourier components are displayed in the on-line block. (See the document “EuroProt+ Remote user interface description”.)



[-] CT4 module		
Current Ch - I1	0.84	A
Angle Ch - I1	-9	deg
Current Ch - I2	0.84	A
Angle Ch - I2	-129	deg
Current Ch - I3	0.85	A
Angle Ch - I3	111	deg
Current Ch - I4	0.00	A
Angle Ch - I4	0	deg

*Figure 6 Example: On-line displayed values for the current input module*

### 1.3.1.25 Voltage input function (VT4)

If the factory configuration includes a voltage transformer hardware module, the voltage input function block is automatically configured among the software function blocks. Separate voltage input function blocks are assigned to each voltage transformer hardware module.

A voltage transformer hardware module is equipped with four special intermediate voltage transformers. (See Chapter 6 of the EuroProt+ hardware description document.) As usual, the first three voltage inputs receive the three phase voltages (UL1, UL2, UL3), the fourth input is reserved for zero sequence voltage or for a voltage from the other side of the circuit breaker for synchron switching. All inputs have a common parameter for type selection: 100V or 200V.

Additionally, there is a correction factor available if the rated secondary voltage of the main voltage transformer (e.g. 110V) does not match the rated input of the device.

The role of the voltage input function block is to

- set the required parameters associated to the voltage inputs,
- deliver the sampled voltage values for disturbance recording,
- perform the basic calculations
  - Fourier basic harmonic magnitude and angle,
  - True RMS value;
- provide the pre-calculated voltage values to the subsequent software modules,
- deliver the basic calculated values for on-line displaying.

#### Operation of the voltage input algorithm

The voltage input function block receives the sampled voltage values from the internal operating system. The scaling (even hardware scaling) depends on parameter setting. See the parameter VT4\_Type\_EPar\_ (Range). The options to choose from are 100V or 200V. This parameter influences the internal number format and, naturally, accuracy. (A small voltage is processed with finer resolution if 100V is selected.)

The connection of the first three VT secondary winding must be set to reflect actual physical connection. The associated parameter is VT4\_Ch13Nom\_EPar\_ (Connection U1-3). The selection can be: Ph-N, Ph-Ph or Ph-N-Isolated.

The Ph-N option is applied in solidly grounded networks, where the measured phase voltage is never above 1.5·Un. In this case the primary rated voltage of the VT must be the value of the rated PHASE-TO-NEUTRAL voltage.

The Ph-N option is applied in compensated or isolated networks, where the measured phase voltage can be above 1.5·Un even in normal operation. In this case the primary rated voltage of the VT must be the value of the rated PHASE-TO-PHASE voltage.

If phase-to-phase voltage is connected to the VT input of the device, then the Ph-Ph option is to be selected. Here, the primary rated voltage of the VT must be the value of the rated PHASE-TO-PHASE voltage. This option must not be selected if the distance protection function is supplied from the VT input.

The fourth input is reserved for zero sequence voltage or for a voltage from the other side of the circuit breaker for synchron switching. Accordingly, the connected voltage must be identified with parameter setting VT4\_Ch4Nom\_EPar\_ (Connection U4). Here, phase-to-neutral or phase-to-phase voltage can be selected: Ph-N, Ph-Ph

If needed, the phase voltages can be inverted by setting the parameter VT4\_Ch13Dir\_EPar\_ (Direction U1-3). This selection applies to each of the channels UL1, UL2 and UL3. The fourth voltage channel can be inverted by setting the parameter VT4\_Ch4Dir\_EPar\_ (Direction U4). This inversion may be needed in protection functions such as distance protection, differential protection or for any functions with directional decision, or for checking the voltage vector positions.

Additionally, there is a correction factor available if the rated secondary voltage of the main voltage transformer (e.g. 110V) does not match the rated input of the device. The related parameter is VT4\_CorrFact\_IPar\_ (VT correction). As an example: if the rated secondary voltage of the main voltage transformer is 110V, then select Type 100 for the parameter "Range" and the required value to set here is 110%.

These sampled values are available for further processing and for disturbance recording.

The performed basic calculation results the Fourier basic harmonic magnitude and angle and the true RMS value of the voltages. These results are processed by subsequent protection function blocks and they are available for on-line displaying as well.

The function block also provides parameters for setting the primary rated voltages of the main voltage transformer. This function block does not need that parameter setting. These values are passed on to function blocks such as displaying primary measured values, primary power calculation, etc. Concerning the rated voltage, see the instructions related to the parameter for the connection of the first three VT secondary winding.

### Parameters

#### Enumerated parameters

Parameter name	Title	Selection range	Default
Rated secondary voltage of the input channels. 100 V or 200V is selected by parameter setting, no hardware modification is needed.			
VT4_Type_EPar_	Range	Type 100,Type 200	Type 100
Connection of the first three voltage inputs (main VT secondary)			
VT4_Ch13Nom_EPar_	Connection U1-3	Ph-N, Ph-Ph, Ph-N-Isolated	Ph-N
Selection of the fourth channel input: phase-to-neutral or phase-to-phase voltage			
VT4_Ch4Nom_EPar_	Connection U4	Ph-N,Ph-Ph	Ph-Ph
Definition of the positive direction of the first three input channels, given as normal or inverted			
VT4_Ch13Dir_EPar_	Direction U1-3	Normal,Inverted	Normal
Definition of the positive direction of the fourth voltage, given as normal or inverted			
VT4_Ch4Dir_EPar_	Direction U4	Normal,Inverted	Normal

Table 115 The enumerated parameters of the voltage input function

#### Integer parameter

Parameter name	Title	Unit	Min	Max	Step	Default
Voltage correction						
VT4_CorrFact_IPar_	VT correction	%	100	115	1	100

Table 116 The integer parameter of the voltage input function

#### Floating point parameters

Parameter name	Title	Dim.	Min	Max	Default
Rated primary voltage of channel1					
VT4_PriU1_FPar	Rated Primary U1	kV	1	1000	100
Rated primary voltage of channel2					
VT4_PriU2_FPar	Rated Primary U2	kV	1	1000	100
Rated primary voltage of channel3					
VT4_PriU3_FPar	Rated Primary U3	kV	1	1000	100
Rated primary voltage of channel4					
VT4_PriU4_FPar	Rated Primary U4	kV	1	1000	100

Table 117 The floating point parameters of the voltage input function

NOTE: The rated primary voltage of the channels is not needed for the voltage input function block itself. These values are passed on to the subsequent function blocks.

Function	Range	Accuracy
Voltage accuracy	30% ... 130%	< 0.5 %

Table 118 Technical data of the voltage input

#### Measured values

Measured value	Dim.	Explanation
Voltage Ch - U1	V(secondary)	Fourier basic component of the voltage in channel UL1
Angle Ch - U1	degree	Vector position of the voltage in channel UL1
Voltage Ch - U2	V(secondary)	Fourier basic component of the voltage in channel UL2
Angle Ch - U2	degree	Vector position of the voltage in channel UL2
Voltage Ch - U3	V(secondary)	Fourier basic component of the voltage in channel UL3
Angle Ch - U3	degree	Vector position of the voltage in channel UL3
Voltage Ch - U4	V(secondary)	Fourier basic component of the voltage in channel U4
Angle Ch - U4	degree	Vector position of the voltage in channel U4

Table 119 The measured analogue values of the voltage input function

NOTE1: The scaling of the Fourier basic component is such if pure sinusoid 57V RMS of the rated frequency is injected, the displayed value is 57V. (The displayed value does not depend on the parameter setting values "Rated Secondary".)

NOTE2: The reference vector (vector with angle 0 degree) is the vector calculated for the first voltage input channel of the first applied voltage input module.

The figure below shows an example of how the calculated Fourier components are displayed in the on-line block. (See the document EuroProt+ "Remote user interface description".)

[-] VT4 module		
Voltage Ch - U1	56.75	V
Angle Ch - U1	0	deg
Voltage Ch - U2	51.46	V
Angle Ch - U2	-112	deg
Voltage Ch - U3	60.54	V
Angle Ch - U3	128	deg
Voltage Ch - U4	0.00	V
Angle Ch - U4	0	deg

Figure 7 Example: On-line displayed values for the voltage input module



### 1.3.1.26 Circuit breaker control function block (CB1Pol)

The Circuit breaker control function block can be used to integrate the circuit breaker control of the EuroProt+ device into the station control system and to apply active scheme screens of the local LCD of the device.

The Circuit breaker control function block receives remote commands from the SCADA system and local commands from the local LCD of the device, performs the prescribed checking and transmits the commands to the circuit breaker. It processes the status signals received from the circuit breaker and offers them to the status display of the local LCD and to the SCADA system.

Main features:

- Local (LCD of the device) and Remote (SCADA) operation modes can be enabled or disabled individually.
- The signals and commands of the synchro check / synchro switch function block can be integrated into the operation of the function block.
- Interlocking functions can be programmed by the user applying the inputs “EnaOff” (enabled trip command) and “EnaOn” (enabled close command), using the graphic equation editor.
- Programmed conditions can be used to temporarily disable the operation of the function block using the graphic equation editor.
- The function block supports the control models prescribed by the IEC 61850 standard.
- All necessary timing tasks are performed within the function block:
  - Time limitation to execute a command
  - Command pulse duration
  - Filtering the intermediate state of the circuit breaker
  - Checking the synchro check and synchro switch times
  - Controlling the individual steps of the manual commands
- Sending trip and close commands to the circuit breaker (to be combined with the trip commands of the protection functions and with the close command of the automatic reclosing function; the protection functions and the automatic reclosing function directly gives commands to the CB). The combination is made graphically using the graphic equation editor
- Operation counter
- Event reporting

The Circuit breaker control function block has binary input signals. The conditions are defined by the user applying the graphic equation editor. The signals of the circuit breaker control are seen in the binary input status list.

#### Technical data

Function	Accuracy
Operate time accuracy	±5% or ±15 ms, whichever is greater

*Table 120 Technical data of the circuit breaker control function*

**Parameters****Enumerated parameter**

Parameter name	Title	Selection range	Default
The control model of the circuit breaker node according to the IEC 61850 standard			
CB1Pol_ctlMod_EPar_	ControlModel*	Direct normal, Direct enhanced, SBO enhanced	Direct normal

*\*ControlModel*

- Direct normal: only command transmission
- Direct enhanced: command transmission with status check and command supervision
- SBO enhanced: Select Before Operate mode with status check and command supervision

*Table 121 Enumerated parameter of the circuit breaker control function***Boolean parameter**

Boolean parameter	Title	Explanation
CB1Pol_DisOverR_BPar_	Forced check	If true, then the check function cannot be neglected by the check attribute defined by the IEC 61850 standard

*Table 122 Boolean parameter of the circuit breaker control function***Timer parameters**

Parameter name	Title	Unit	Min	Max	Step	Default
Timeout for signaling failed operation						
CB1Pol_TimOut_TPar_	Max.Operating time	msec	10	1000	1	200
Duration of the generated On and Off impulse						
CB1Pol_Pulse_TPar_	Pulse length	msec	50	500	1	100
Waiting time, at expiry intermediate state of the CB is reported						
CB1Pol_MidPos_TPar_	Max.Intermediate time	msec	20	30000	1	100
Length of the time period to wait for the conditions of the synchron state. After expiry of this time, the synchro switch procedure is initiated (see synchro check/ synchro switch function block description)						
CB1Pol_SynTimOut_TPar_	Max.SynChk time	msec	10	5000	1	1000
Length of the time period to wait for the synchro switch impulse (see synchro check/ synchro switch function block description). After this time the function resets, no switching is performed						
CB1Pol_SynSWTimOut_TPar_	Max.SynSW time*	msec	0	60000	1	0
Duration of the waiting time between object selection and command selection. At timeout no command is performed						
CB1Pol_SBOTimeout_TPar_	SBO Timeout	msec	1000	20000	1	5000

\* If this parameter is set to 0, then the "StartSW" output is not activated

*Table 123 Timer parameters of the circuit breaker control function*

**Available internal status variable and command channel**

To generate an active scheme on the local LCD, there is an internal status variable indicating the state of the circuit breaker. Different graphic symbols can be assigned to the values. (See Chapter 3.2 of the document “EuroCAP configuration tool for EuroProt+ devices”).

Status variable	Title	Explanation
CB1Pol_stVal Ist_	Status	Can be: 0: Intermediate 1: Off 2: On 3: Bad

The available control channel to be selected is:

Command channel	Title	Explanation
CB1Pol_Oper_Con_	Operation	Can be: On Off

Using this channel, the pushbuttons on the front panel of the device can be assigned to close or open the circuit breaker. These are the “Local commands”.

### 1.3.1.27 Disconnecter control function (DisConn)

The Disconnecter control function block can be used to integrate the disconnecter control of the EuroProt+ device into the station control system and to apply active scheme screens of the local LCD of the device.

The Disconnecter control function block receives remote commands from the SCADA system and local commands from the local LCD of the device, performs the prescribed checking and transmits the commands to the disconnecter. It processes the status signals received from the disconnecter and offers them to the status display of the local LCD and to the SCADA system.

Main features:

- Local (LCD of the device) and Remote (SCADA) operation modes can be enabled or disabled individually.
- Interlocking functions can be programmed by the user applying the inputs “EnaOff” (enabled trip command) and “EnaOn” (enabled close command), using the graphic equation editor.
- Programmed conditions can be used to temporarily disable the operation of the function block using the graphic equation editor.
- The function block supports the control models prescribed by the IEC 61850 standard.
- All necessary timing tasks are performed within the function block:
  - Time limitation to execute a command
  - Command pulse duration
  - Filtering the intermediate state of the disconnecter
  - Controlling the individual steps of the manual commands
- Sending trip and close commands to the disconnecter
- Operation counter
- Event reporting

The Disconnecter control function block has binary input signals. The conditions are defined by the user applying the graphic equation editor. The signals of the disconnecter control are seen in the binary input status list.

#### Technical data

Function	Accuracy
Operate time accuracy	±5% or ±15 ms, whichever is greater

Table 124 Technical data of the disconnecter control function

#### Parameters

##### Enumerated parameters

Parameter name	Title	Selection range	Default
The control model of the disconnecter node according to the IEC 61850 standard			
DisConn_ctlMod_EPar_	ControlModel*	Direct normal, Direct enhanced, SBO enhanced	Direct normal
Type of switch			
DisConn_SwTyp_EPar_	Type of Switch	N/A, Load break, Disconnecter, Earthing Switch, HS Earthing Switch	Disconnecter

\*ControlModel

- Direct normal: only command transmission
- Direct enhanced: command transmission with status check and command supervision
- SBO enhanced: Select Before Operate mode with status check and command supervision

Table 125 Enumerated parameters of the disconnecter control function

**Boolean parameter**

Boolean parameter	Title	Explanation
DisConn_DisOverR_BPar_	Forced check	If true, then the check function cannot be neglected by the check attribute defined by the IEC 61850 standard

*Table 126 Boolean parameter of the disconnector control function*

**Timer parameters**

Parameter name	Title	Unit	Min	Max	Step	Default
Timeout for signaling failed operation						
DisConn_TimOut_TPar_	Max.Operating time	msec	10	20000	1	1000
Duration of the generated On and Off impulse						
DisConn_Pulse_TPar_	Pulse length	msec	50	30000	1	100
Waiting time, at expiry intermediate state of the disconnector is reported						
DisConn_MidPos_TPar_	Max.Intermediate time	msec	20	30000	1	100
Duration of the waiting time between object selection and command selection. At timeout no command is performed						
DisConn_SBOTimeout_TPar_	SBO Timeout	msec	1000	20000	1	5000

*Table 127 Timer parameters of the disconnector control function*

**Available internal status variable and command channel**

To generate an active scheme on the local LCD, there is an internal status variable indicating the state of the disconnector. Different graphic symbols can be assigned to the values. (See Chapter 3.2 of the document “EuroCAP configuration tool for EuroProt+ devices”).

Status variable	Title	Explanation
DisConn_l_stVal_lst_	Status	Can be: 0: Intermediate 1: Off 2: On 3:Bad

The available control channel to be selected is:

Command channel	Title	Explanation
DisConn_Oper_Con_	Operation	Can be: On Off

Using this channel, the pushbuttons on the front panel of the device can be assigned to close or open the disconnector. These are the “Local commands”.

### 1.3.1.28 Line measurement function (MXU)

#### The measurement

The input values of the EuroProt+ devices are the secondary signals of the voltage transformers and those of the current transformers.

These signals are pre-processed by the “Voltage transformer input” function block and by the “Current transformer input” function block. These function blocks are described in separate documents. The pre-processed values include the Fourier basic harmonic phasors of the voltages and currents and the true RMS values. Additionally, it is in these function blocks that parameters are set concerning the voltage ratio of the primary voltage transformers and current ratio of the current transformers.

Based on the pre-processed values and the measured transformer parameters, the “Line measurement” function block calculates - depending on the hardware and software configuration - the primary RMS values of the voltages and currents and some additional values such as active and reactive power, symmetrical components of voltages and currents. These values are available as primary quantities and they can be displayed on the on-line screen of the device or on the remote user interface of the computers connected to the communication network and they are available for the SCADA system using the configured communication system.

#### Reporting the measured values and the changes

It is usual for the SCADA systems that they sample the measured and calculated values in regular time periods and additionally they receive the changed values as reports at the moment when any significant change is detected in the primary system. The “Line measurement” function block is able to perform such reporting for the SCADA system.

#### Operation of the line measurement function block

The **inputs** of the line measurement function are

- the Fourier components and true RMS values of the measured voltages and currents,
- frequency measurement,
- parameters.

The **outputs** of the line measurement function are

- displayed measured values,
- reports to the SCADA system.

NOTE: the scaling values are entered as parameter setting for the “Voltage transformer input” function block and for the “Current transformer input” function block.

#### The measured values

The **measured values** of the line measurement function depend on the hardware configuration. As an example, Table 128 shows the list of the measured values available in a configuration for solidly grounded networks.

Measured value	Explanation
MXU_P_OLM	Active Power – P (Fourier base harmonic value)
MXU_Q_OLM	Reactive Power – Q (Fourier base harmonic value)
MXU_S_OLM	Apparent Power – S (Fourier base harmonic value)
MXU_I1_OLM	Current L1
MXU_I2_OLM	Current L2
MXU_I3_OLM	Current L3
MXU_U1_OLM	Voltage L1
MXU_U2_OLM	Voltage L2
MXU_U3_OLM	Voltage L3
MXU_U12_OLM	Voltage L12
MXU_U23_OLM	Voltage L23
MXU_U31_OLM	Voltage L31
MXU_f_OLM	Frequency

Table 128 Example: Measured values in a configuration for solidly grounded networks

Another example is Figure 8, where the measured values available are shown as on-line information in a configuration for compensated networks.

[-] Line measurement		
Active Power - P	17967.19	kW
Reactive Power - Q	10414.57	kVAr
Current L1	97	A
Current L2	97	A
Current L3	97	A
Voltage L12	120.0	kV
Voltage L23	120.0	kV
Voltage L31	120.0	kV
Residual Voltage	0.0	kV
Frequency	50.00	Hz

Figure 8 Example: Measured values in a configuration for compensated networks

The available quantities are described in the configuration description documents.

### Reporting the measured values and the changes

For reporting, additional information is needed, which is defined in parameter setting. As an example, in a configuration for solidly grounded networks the following parameters are available:

**Enumerated parameters**

Parameter name	Title	Selection range	Default
Selection of the reporting mode for active power measurement			
MXU_PRepMode_EPar_	Operation ActivePower	Off, Amplitude, Integrated	Amplitude
Selection of the reporting mode for reactive power measurement			
MXU_QRepMode_EPar_	Operation ActivePower	Off, Amplitude, Integrated	Amplitude
Selection of the reporting mode for apparent power measurement			
MXU_SRepMode_EPar_	Operation ApparPower	Off, Amplitude, Integrated	Amplitude
Selection of the reporting mode for current measurement			
MXU_IRepMode_EPar_	Operation Current	Off, Amplitude, Integrated	Amplitude
Selection of the reporting mode for voltage measurement			
MXU_URepMode_EPar_	Operation Voltage	Off, Amplitude, Integrated	Amplitude
Selection of the reporting mode for frequency measurement			
MXU_fRepMode_EPar_	Operation Frequency	Off, Amplitude, Integrated	Amplitude

*Table 129 The enumerated parameters of the line measurement function*

The selection of the reporting mode items is explained in Figure 9 and in Figure 10.

**“Amplitude” mode of reporting**

If the “Amplitude” mode is selected for reporting, a report is generated if the measured value leaves the deadband around the previously reported value. As an example, Figure 9 shows that the current becomes higher than the value reported in “report1” PLUS the Deadband value, this results “report2”, etc.

For this mode of operation, the Deadband parameters are explained in Table 130.

The “Range” parameters in Table 130 are needed to evaluate a measurement as “out-of-range”.



**Floating point parameters**

Parameter name	Title	Dim.	Min	Max	Step	Default
Deadband value for the active power						
MXU_PDeadB_FPar_	Deadband value - P	MW	0.1	100000	0.01	10
Range value for the active power						
MXU_PRange_FPar_	Range value - P	MW	1	100000	0.01	500
Deadband value for the reactive power						
MXU_QDeadB_FPar_	Deadband value - Q	MVAr	0.1	100000	0.01	10
Range value for the reactive power						
MXU_QRange_FPar_	Range value - Q	MVAr	1	100000	0.01	500
Deadband value for the apparent power						
MXU_SDeadB_FPar_	Deadband value - S	MVA	0.1	100000	0.01	10
Range value for the apparent power						
MXU_SRange_FPar_	Range value - S	MVA	1	100000	0.01	500
Deadband value for the current						
MXU_IDeadB_FPar_	Deadband value - I	A	1	2000	1	10
Range value for the current						
MXU_IRange_FPar_	Range value - I	A	1	5000	1	500
Deadband value for the phase-to-neutral voltage						
MXU_UPhDeadB_FPar_	Deadband value – U ph-N	kV	0.1	100	0.01	1
Range value for the phase-to-neutral voltage						
MXU_UPhRange_FPar_	Range value – U ph-N	kV	1	1000	0.1	231
Deadband value for the phase-to-phase voltage						
MXU_UPPDeadB_FPar_	Deadband value – U ph-ph	kV	0.1	100	0.01	1
Range value for the phase-to-phase voltage						
MXU_UPPRange_FPar_	Range value – U ph-ph	kV	1	1000	0.1	400
Deadband value for the current						
MXU_fDeadB_FPar_	Deadband value - f	Hz	0.01	1	0.01	0.02
Range value for the current						
MXU_fRange_FPar_	Range value - f	Hz	0.05	10	0.01	5

*Table 130 The floating-point parameters of the line measurement function*

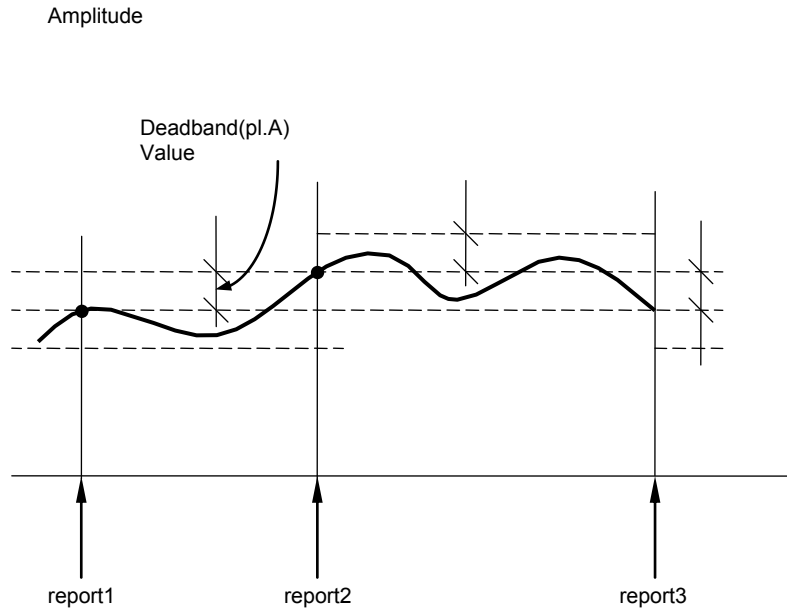

Figure 9 Reporting if “Amplitude” mode is selected

**“Integral” mode of reporting**

If the “Integrated” mode is selected for reporting, a report is generated if the time integral of the measured value since the last report gets becomes larger, in the positive or negative direction larger, than the (deadband\*1sec) area. As an example, Figure 10 shows that the integral of the current in time becomes higher than the Deadband value multiplied by 1sec, this results “report2”, etc.

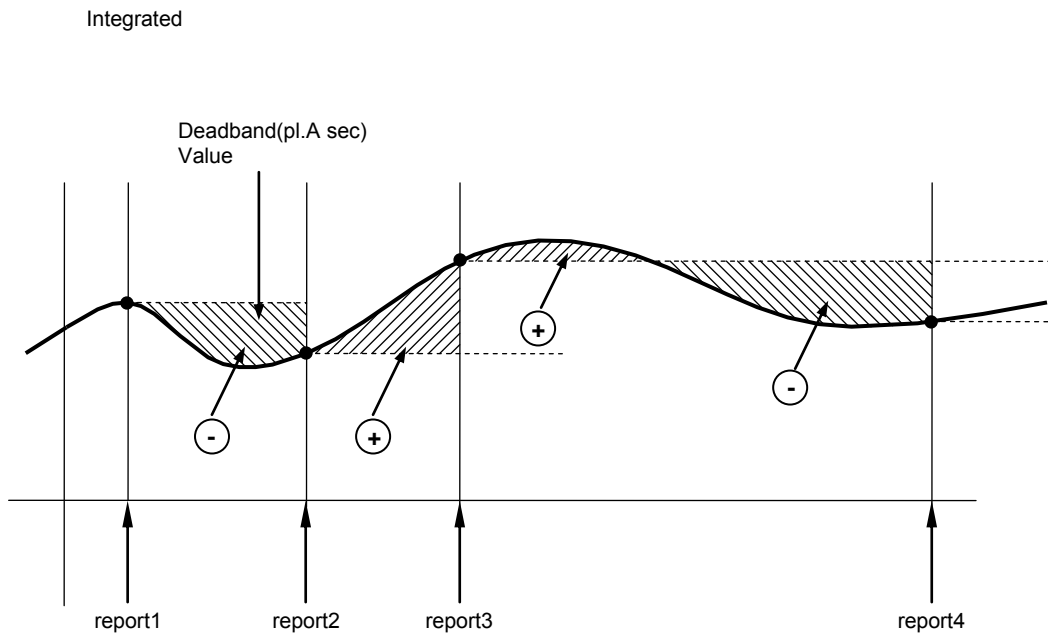

Figure 10 Reporting if “Integrated” mode is selected

### Periodic reporting

Periodic reporting is generated independently of the changes of the measured values when the defined time period elapses. The required parameter setting is shown in Table 131.

#### Integer parameters

Parameter name	Title	Unit	Min	Max	Step	Default
Reporting time period for the active power						
MXU_PIntPer_IPar_	Report period P	sec	0	3600	1	0
Reporting time period for the reactive power						
MXU_QIntPer_IPar_	Report period Q	sec	0	3600	1	0
Reporting time period for the apparent power						
MXU_SIntPer_IPar_	Report period S	sec	0	3600	1	0
Reporting time period for the voltage						
MXU_UIntPer_IPar_	Report period U	sec	0	3600	1	0
Reporting time period for the current						
MXU_IIntPer_IPar_	Report period I	sec	0	3600	1	0
Reporting time period for the frequency						
MXU_fIntPer_IPar_	Report period f	sec	0	3600	1	0

Table 131 The integer parameters of the line measurement function

If the reporting time period is set to 0, then no periodic reporting is performed for this quantity.

All reports can be disabled for a quantity if the reporting mode is set to "Off". See Table 129.

### Technical data

Function	Range	Accuracy
Current accuracy		
with CT/5151 or CT/5102 modules	0,2 In – 0,5 In	±2%, ±1 digit
	0,5 In – 20 In	±1%, ±1 digit
with CT/1500 module	0,03 In – 2 In	±0,5%, ±1 digit
Voltage accuracy	5 – 150% of Un	±0.5% of Un, ±1 digit
Power accuracy	I>5% In	±3%, ±1 digit
Frequency accuracy	U>3.5%Un 45Hz – 55Hz	2mHz

Table 132 Technical data of line measurement

## 2 External connections

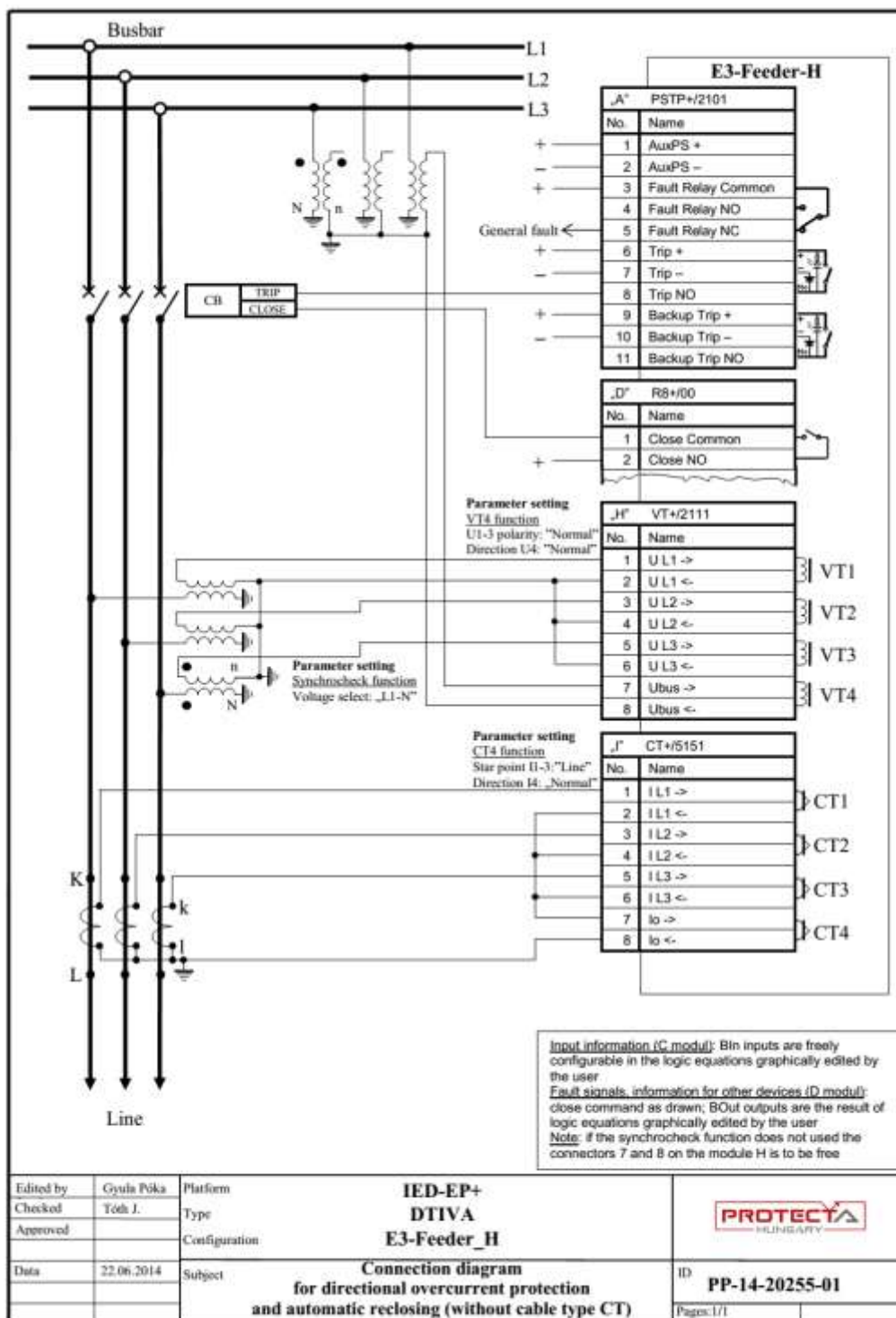

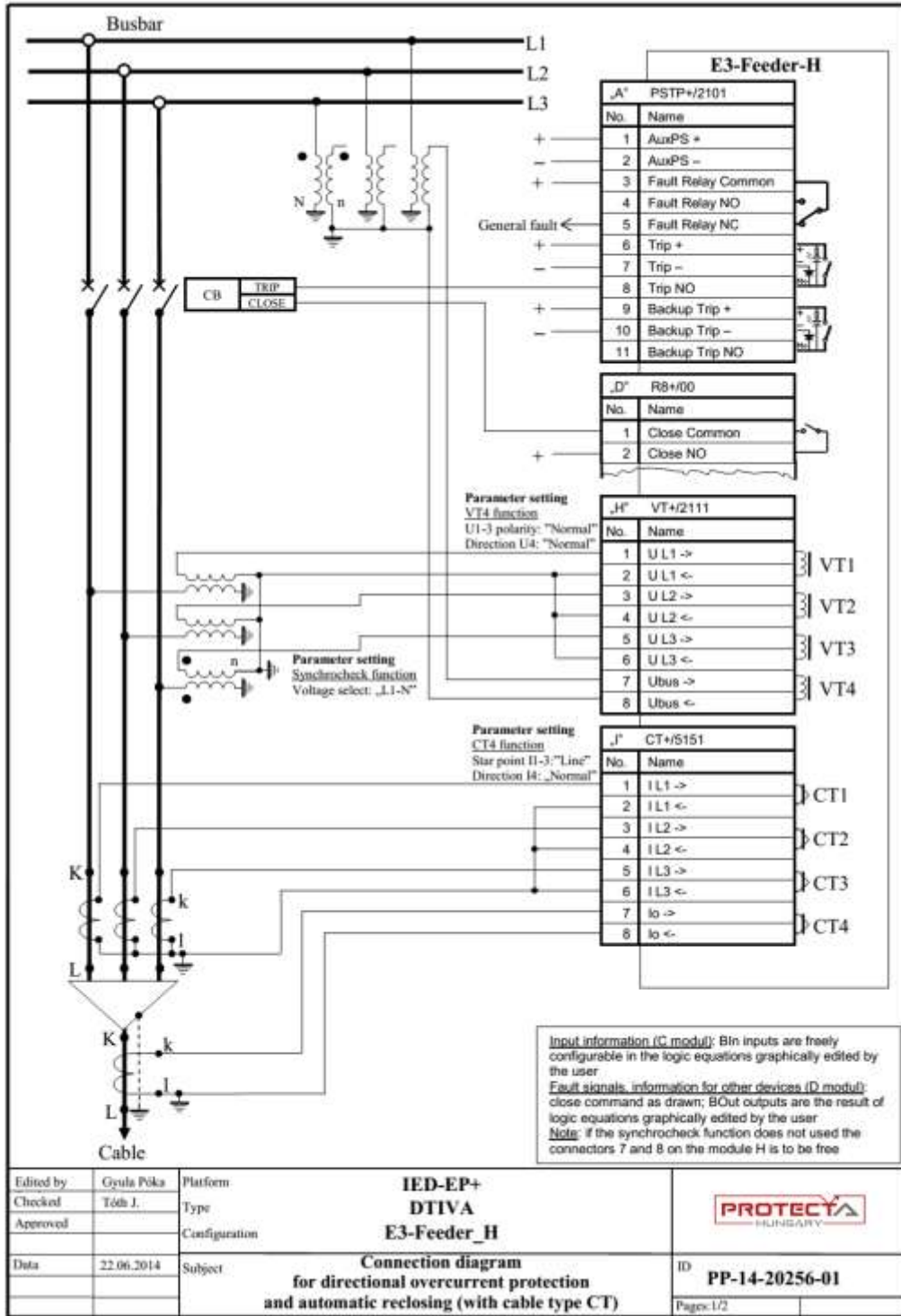

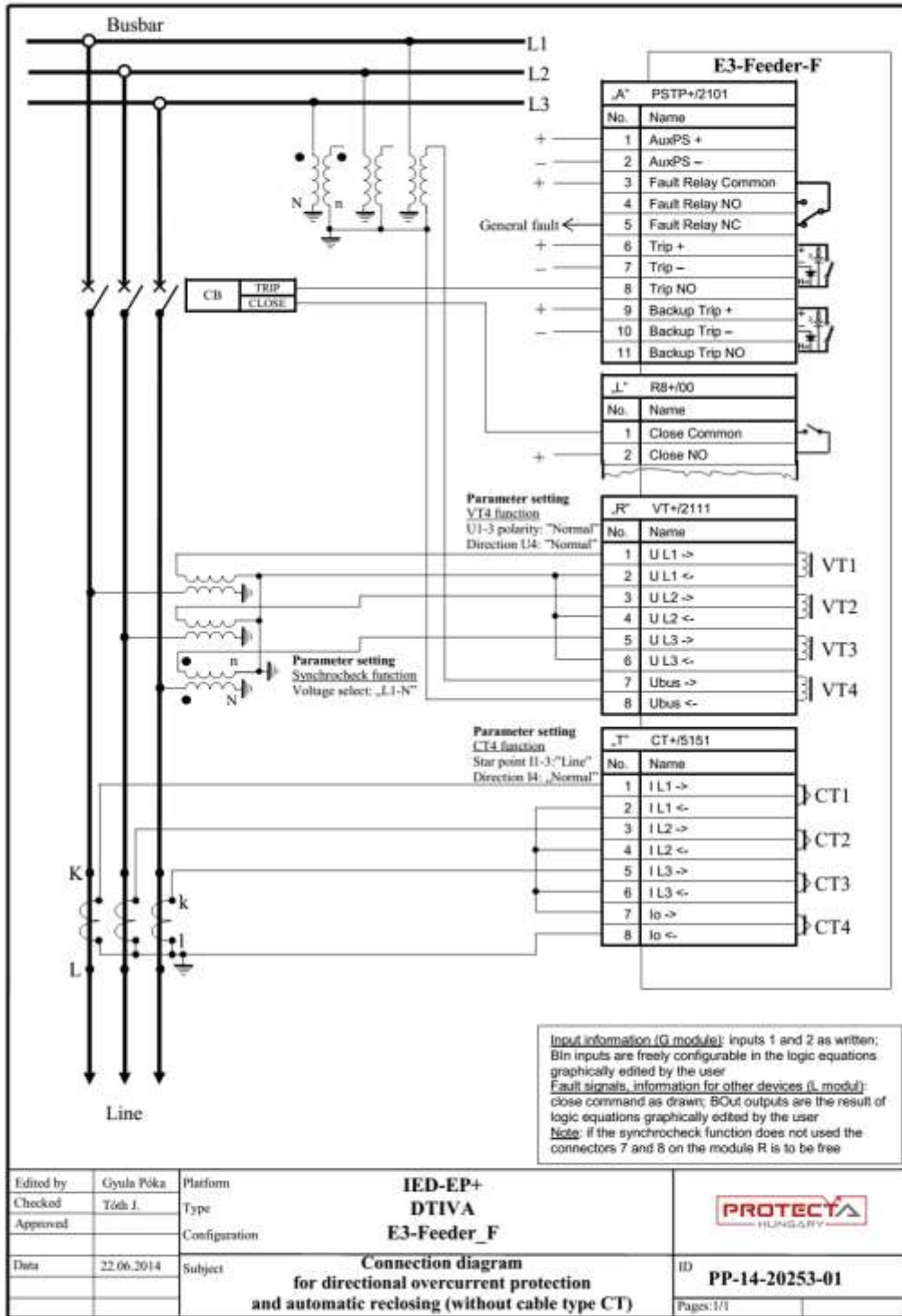

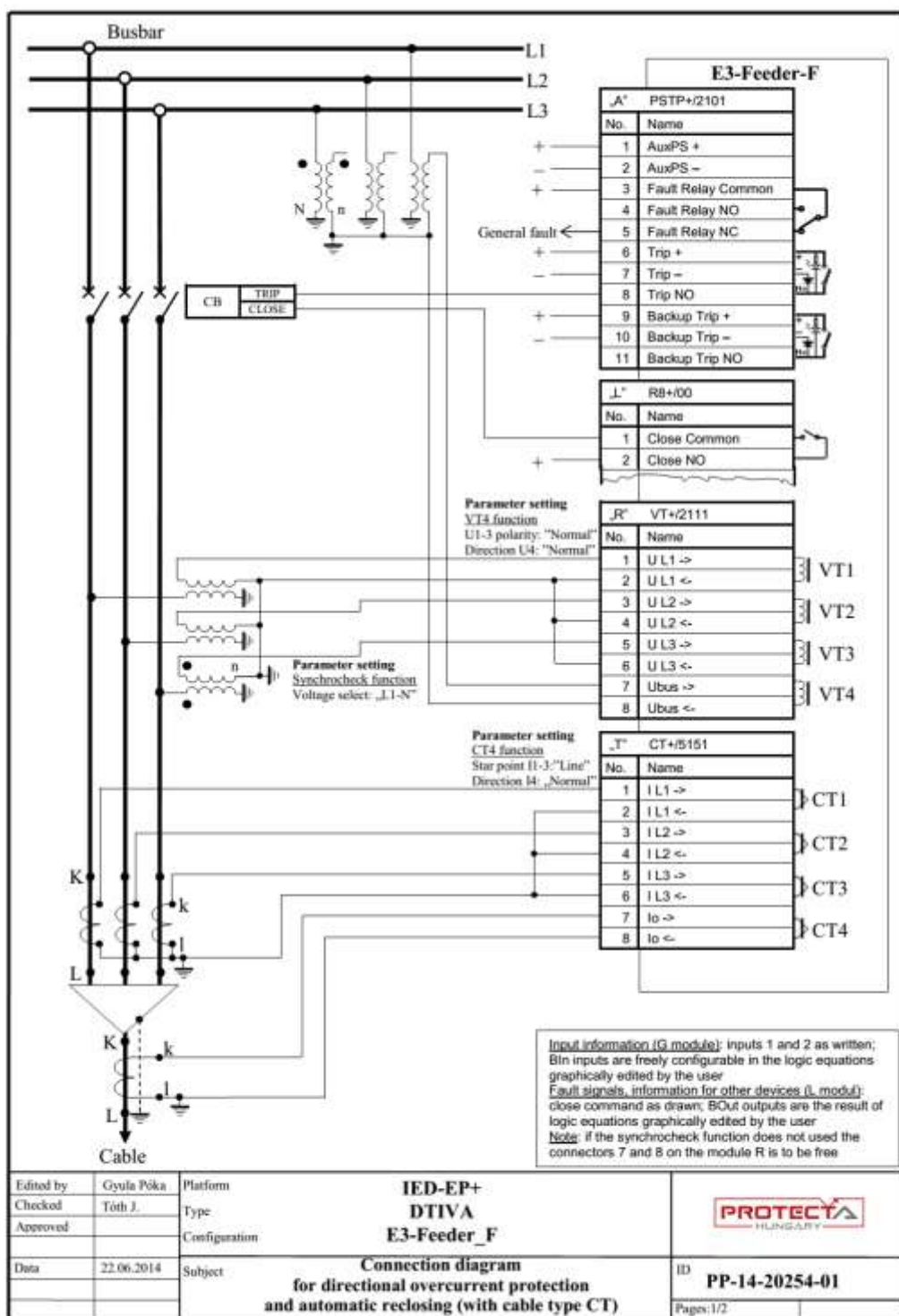

*The performances and the characteristics reported in this manual are not binding and can modified at any moment without notice.*

**MICROENER**

Quartier du Pavé Neuf - 49 rue de l'université  
F-93191 NOISY LE GRAND  
TEL. : +33 1 48 15 09 09 - FAX. : +33 1 43 05 08 24  
Email : [info@microener.com](mailto:info@microener.com) - URL : <http://www.microener.com>